

Low voltage

EasyPact SPS

LV power circuit breakers and switch-disconnectors
800 to 1600A

Catalogue
2013



Functions and characteristics	A-1
----------------------------------	-----

Installation recommendations	B-1
---------------------------------	-----

Dimensions and connection	C-1
------------------------------	-----

Electrical diagrams	D-1
---------------------	-----

Additional characteristics	E-1
-------------------------------	-----

Catalogue numbers and order form	F-1
-------------------------------------	-----

Functions and characteristics



General overview	A-2
Detailed contents	A-2
Circuit breakers and switch-disconnectors	A-4
SPS08 to SPS16	A-4
Identifying ET range of trip system	A-6
Overview of functions	A-7
ET trip system	A-7
ET range of trip system	A-9
Accessories and test equipment	A-9
Connections	A-10
Overview of solutions and accessories	A-10
Accessories and auxiliaries	A-11
Locking	A-13
On the device	A-13
On the chassis	A-14
Indication contacts	A-15
Remote operation	A-16
Remote ON / OFF	A-16
Remote tripping	A-18
Source-changeover systems	A-19
Mechanical interlocking	A-19
Accessories	A-20
<i>Installation recommendations</i>	<i>B-1</i>
<i>Dimensions and connection</i>	<i>C-1</i>
<i>Electrical diagrams</i>	<i>D-1</i>
<i>Additional characteristics</i>	<i>E-1</i>
<i>Catalogue numbers and order form</i>	<i>F-1</i>

This overview describes all the functions offered by EasyPact SPS devices.

CPB100000



CDB500000



ET2.0 trip system.

CDB5000002



ET6G trip system.

Circuit breakers and switch-disconnectors page A-4

- Ratings:
 - EasyPact SPS 800 to 1600 A
 - Circuit breakers type F
 - Switch-disconnectors type FA
 - 3 or 4 poles
 - Fixed or drawout versions

ET trip system page A-6

- 2.0 basic protection
- 6G selective + earth-fault protection
- Standard long-time rating plug:
 - Current setting (A) 0.4 to 1 x I_n

Connections page A-10

- Rear connection:
 - Vertical
- Optional accessories:
 - Interphase barriers
 - Spreaders

E-60459



Safety shutters

DB101149



Interphase barriers

Locking page A-13

- Pushbutton locking by padlockable transparent cover
- OFF-position locking by keylock
- Chassis locking in disconnected position by keylock
- Door interlock (inhibits door opening with breaker in 'connected' or 'test' position)

DBE10109

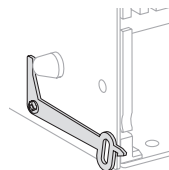

Door interlock

CDB5000039

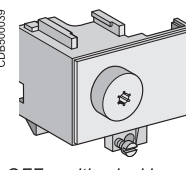

OFF position locking

PB104354A40

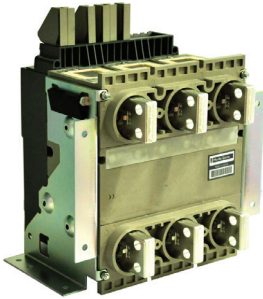

Indication contacts

page A-15

- Standard:
 - ON/OFF indication (OF)
 - "Fault" trip indication (SDE)
- Optional:
 - Additional ON/OFF indication (OF)
 - Ready-to-close contact (PF)
 - Carriage switches for connected (CE) disconnected (CD) and test (CT) positions

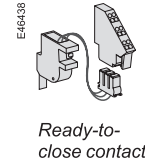

Ready-to-close contact

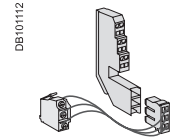

OF contact

CPB100003

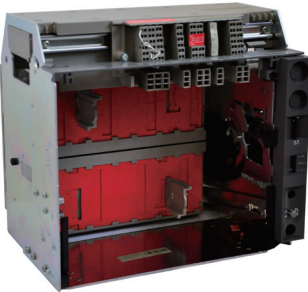

Remote operation

page A-16

- Remote ON/OFF:
 - Gear motor
 - XF closing or MX opening voltage releases
- Remote tripping function:
 - MN voltage release
 - Standard
 - Adjustable or non-adjustable delay

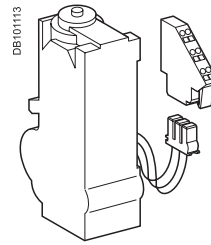

Gear motor

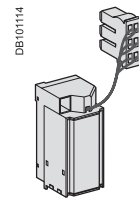

MX, XF and MN voltage releases

CPB100015

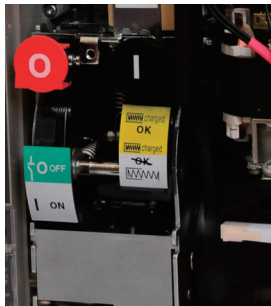

Source-changeover systems

page A-19

- Mechanical interlocking using cables:
 - Interlocking between two devices

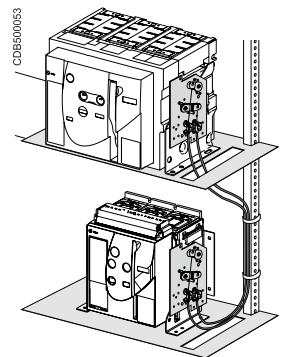

Interlocking of two devices

CPB100016



Accessories

page A-20

- Auxiliary terminal shield
- Escutcheon (Door sealing frame)
- Transparent cover for escutcheon
- Escutcheon blanking plate

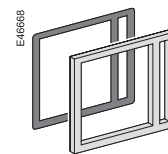

Escutcheon

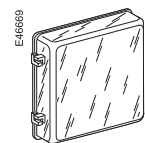

Transparent cover

Circuit breakers and switch-disconnectors

SPS08 to SPS16

CPE100014



Circuit breaker.

CPE100000



Switch-disconnector.

Common characteristics

Number of poles		3/4
Rated insulation voltage (V)	Ui	1000
Impulse withstand voltage (kV)	Uimp	12
Rated operational voltage (V AC 50/60 Hz)	Ue	440
Suitability for isolation	IEC 60947-2	Yes
Degree of pollution	IEC 60664-1	3

Basic circuit-breaker

Circuit-breaker as per IEC 60947-2

Rated current (A)	In	at 40°C ⁽¹⁾
Rating of 4th pole (A)		
Sensor ratings (A)		

Type of circuit breaker

Ultimate breaking capacity (kA rms) V AC 50/60 Hz	Icu	220...440V
Rated service breaking capacity (kA rms)	Ics	% Icu
Utilisation category		
Rated short-time withstand current (kA rms) V AC 50/60 Hz	Icw	1s

Rated making capacity (kA peak) V AC 50/60 Hz	Icm	220...440 V
Breaking time (ms) between tripping order and arc extinction		
Closing time (ms)		

Switch-disconnector as per IEC60947-3 and Annex A

Type of switch-disconnector

Operational current AC23A		
Rated making capacity (kA peak)	Icm	
Rated short-time withstand current (kA rms)	Icw	1s

Maintenance/Connection/Installation

Service life	Mechanical	without maintenance	
C/O cyclesx1000	Electrical	without maintenance	440 V
Connection		Horizontal	
		Vertical	
Dimensions (mm) (H x W x D)	Drawout		3P
			4P
	Fixed		3P
			4P
Weight (kg) (approximate)	Drawout		3P/4P
	Fixed		3P/4P

(1) Refer page no. B-11 for details on temperature derating.

	SPS08	SPS10	SPS12	SPS16
	800	1000	1250	1600
	800	1000	1250	1600
	800	1000	1250	1600
	F	F	F	F
	50	50	50	50
	100%	100%	100%	100%
	B	B	B	B
	42	42	42	42
	105	105	105	105
	25	25	25	25
	<50	<50	<50	<50

	SPS08	SPS10	SPS12	SPS16
	FA	FA	FA	FA
	800	1000	1250	1600
	75	75	75	75
	36	36	36	36
	12.5	12.5	12.5	12.5
	6	6	6	6
	No			
	Yes			
	322 x 288x 277			
	322 x 358x 277			
	301 x 276 x 196			
	301 x 346 x 196			
	30/39			
	14/18			

EasyPact SPS circuit breakers equipped with ET range of trip system are designed to protect power circuit and connected loads.

CPB100011



Dependability

Integration of protection functions in an ASIC electronic component used in all trip units guarantees a high degree of reliability and immunity to conducted or radiated disturbances.

On ET range, protection functions ensure system protection even at very low load currents.

Accessories

Certain functions require the addition of trip unit accessories, described on page A-9.

Trip unit name codes

Type of protection

- 2.0 for basic protection
- 6G for selective + earth-fault protection

ET2.0: basic protection

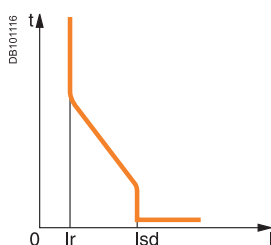

Protection:
long time
+ instantaneous

ET6G: selective + earth-fault protection

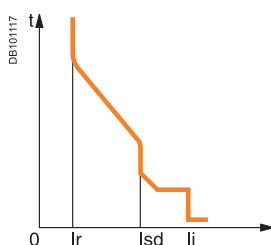

Protection:
long time
+ short time
+ instantaneous
+ earth fault

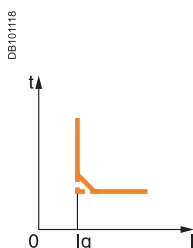

ET trip unit protect power circuits, under overload & short-circuit conditions. ET6G provides earth-fault protection and equipped with individual fault trip indication LEDs.

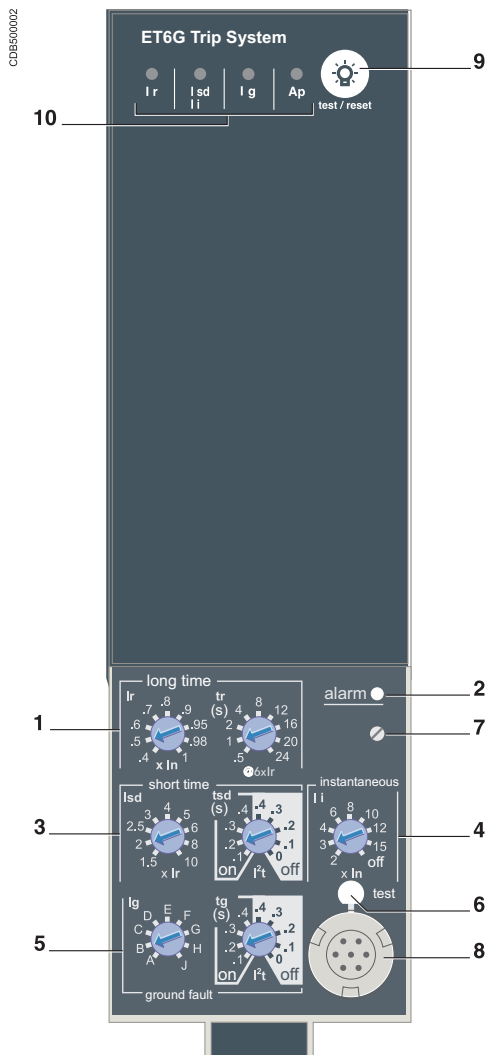

- 1 Long-time threshold and tripping delay.
- 2 Overload alarm (LED) at 1,125 I_r .
- 3 Short-time pick-up and tripping delay.
- 4 Instantaneous pick-up.
- 5 Earth-fault pick-up and tripping delay.
- 6 Earth-fault test button.
- 7 Long-time rating plug screw.
- 8 Test connector.
- 9 Lamp test, reset and battery test.
- 10 Indication of tripping cause.

(1) The thermal memory continuously accounts for the amount of heat in the cables, both before and after tripping, whatever the value of the current (presence of an overload or not). The thermal memory optimises the long-time protection function of the circuit breaker by taking into account the temperature rise in the cables. The thermal memory assumes a cable cooling time of approximately 20 minutes.

(2) Applicable on ET6G trip system

Note: ET trip control units come with a transparent leadseal cover as standard.

Protection

Protection thresholds and delays are set using the adjustment dials.

Overload protection

True rms long-time protection.

Protects cables (phase and neutral) against overloads

Thermal memory⁽¹⁾: thermal image before and after tripping.

Short-time protection

- The short-time protection function protects the distribution system against impedant short-circuits

- The short-time tripping delay can be used to ensure discrimination with downstream circuit breaker (on ET6G)

- The I^2t ON and I^2t OFF options enhance discrimination with a downstream protection devices (on ET6G)

- Use of I^2t curves with short-time protection:

- I^2t OFF selected: the protection function implements a constant time curve

- I^2t ON selected: the protection function implements an I^2t inverse-time curve up to 10 I_r . Above 10 I_r , the time curve is constant

Earth-fault protection on ET6G trip system

Residual earth fault protection.

Selection of I^2t type (ON or OFF) for delay.

A ground fault in the protection conductors can provoke local temperature rise at the site of the fault or in the conductors. The purpose of the ground-fault protection function is to eliminate this type of fault.

Type	Description
Residual	<ul style="list-style-type: none"> ■ The function determines the zero-phase sequence current, i.e. the vectorial sum of the phase and neutral currents ■ It detects faults downstream of the circuit breaker

Instantaneous protection

The Instantaneous-protection function protects the distribution system against solid short-circuits. Contrary to the short-time protection function, the tripping delay for instantaneous protection is not adjustable. The tripping order is sent to the circuit breaker as soon as current exceeds the set value, with a fixed time delay of 20 milliseconds.

Neutral protection

On three-pole circuit breakers, neutral protection is not possible.

On four-pole circuit breakers, neutral protection may be set using a three-position switch: neutral unprotected (4P 3d), neutral protection at 0.5 I_r (4P 3d + N/2), neutral protection at I_r (4P 4d).

Overload alarm

A yellow alarm LED goes on when the current exceeds the long-time trip threshold.

Fault indications⁽²⁾

LEDs indicate the type of fault:

- Overload (long-time protection I_r)
- Short-circuit (short-time I_{sd} or instantaneous I_i protection)
- Earth fault (I_g)
- Internal fault (A_p)

Battery power

The fault indicating LEDs are powered by an in-built battery. The fault indication LEDs remain on until the test/reset button is pressed.

Test

A hand-held test kit may be connected to the test connector on the front to check circuit-breaker operation. For ET6G trip unit, the operation of earth-fault protection can be checked by pressing the test button located above the test connector.

Protection ET2.0

Long time		ET2.0											
Current setting (A)	$I_r = I_n \times \dots$	0.4	0.5	0.6	0.7	0.8	0.9	0.95	0.98	1			
Tripping between 1.05 and 1.20 x I_r													
Time setting		tr (s)	0.5	1	2	4	8	12	16	20	24		
Time delay (s)	Accuracy: 0 to -30 %	$1.5 \times I_r$	12.5	25	50	100	200	300	400	500	600		
	Accuracy: 0 to -20 %	$6 \times I_r$	0.7 ⁽¹⁾	1	2	4	8	12	16	20	24		
	Accuracy: 0 to -20 %	$7.2 \times I_r$	0.7 ⁽²⁾	0.69	1.38	2.7	5.5	8.3	11	13.8	16.6		
Thermal memory		20 minutes before and after tripping											
<i>(1) 0 to -40 % - (2) 0 to -60 %</i>													
Instantaneous													
Pick-up (A)	$I_{sd} = I_r \times \dots$	1.5	2	2.5	3	4	5	6	8	10			
Accuracy: $\pm 10\%$													
Time delay		Max resettable time: 20 ms Max break time: 80 ms											

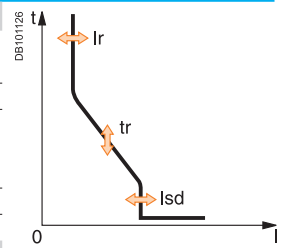

Protection ET6G

Long time		ET6G											
Current setting (A)	$I_r = I_n \times \dots$	0.4	0.5	0.6	0.7	0.8	0.9	0.95	0.98	1			
Tripping between 1.05 and 1.20 x I_r													
Time setting		tr (s)	0.5	1	2	4	8	12	16	20	24		
Time delay (s)	Accuracy: 0 to -30 %	$1.5 \times I_r$	12.5	25	50	100	200	300	400	500	600		
	Accuracy: 0 to -20 %	$6 \times I_r$	0.7 ⁽¹⁾	1	2	4	8	12	16	20	24		
	Accuracy: 0 to -20 %	$7.2 \times I_r$	0.7 ⁽²⁾	0.69	1.38	2.7	5.5	8.3	11	13.8	16.6		
Thermal memory		20 minutes before and after tripping											
<i>(1) 0 to -40 % - (2) 0 to -60 %</i>													
Short time													
Pick-up (A)	$I_{sd} = I_r \times \dots$	1.5	2	2.5	3	4	5	6	8	10			
Accuracy: $\pm 10\%$													
Time setting tsd (s)	Settings	I^2t Off	0	0.1	0.2	0.3	0.4						
		I^2t On	-	0.1	0.2	0.3	0.4						
Time delay (ms) at 10 x I_r (I^2t Off or I^2t On)	tsd (max resettable time)		20	80	140	230	350						
	tsd (max break time)		80	140	200	320	500						
Instantaneous													
Pick-up (A)	$I_i = I_n \times \dots$	2	3	4	6	8	10	12	15	off			
Accuracy: $\pm 10\%$													
Time delay		Max resettable time: 20 ms Max break time: 50 ms											
Earth fault		ET6G											
Pick-up (A)	$I_g = I_n \times \dots$	A	B	C	D	E	F	G	H	J			
Accuracy: $\pm 10\%$	$I_n \leq 400$ A	0.3	0.3	0.4	0.5	0.6	0.7	0.8	0.9	1			
	$400 < I_n \leq 1000$ A	0.2	0.3	0.4	0.5	0.6	0.7	0.8	0.9	1			
	$I_n \geq 1250$ A	500	640	720	800	880	960	1040	1120	1200			
Time setting tg (s)	Settings	I^2t Off	0	0.1	0.2	0.3	0.4						
		I^2t On	-	0.1	0.2	0.3	0.4						
Time delay (ms) at I_n or 1200 A (I^2t Off or I^2t On)	tg (max resettable time)		20	80	140	230	350						
	tg (max break time)		80	140	200	320	500						

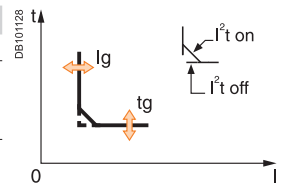
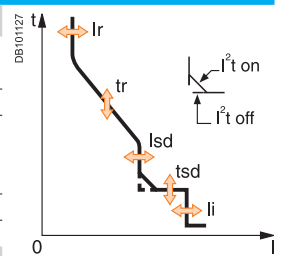

Note: All current-based protection functions require no auxiliary source.
The test / reset button, clears the tripping indication and tests the battery.

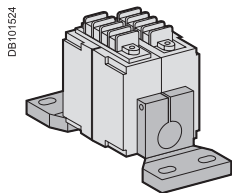

External sensor (CT).

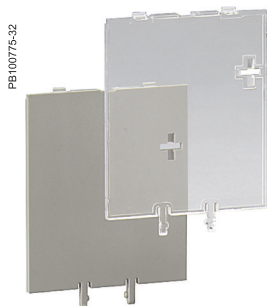

Lead-seal cover.

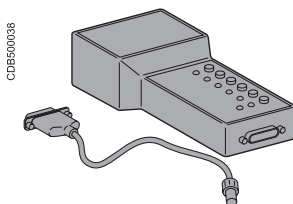

Hand-held test kit.

External sensors

External sensor for earth-fault protection

The sensors, used with the 3P circuit breakers, are installed on the neutral conductor for:

- Residual type earth-fault protection (with ET6G trip units)

The rating of the sensor (CT) must be compatible with the rating of the circuit breaker:

- SPS08 to SPS16: TC 400/1600

Spare parts

Lead-seal covers

A lead-seal cover controls access to the adjustment dials.

When the cover is closed:

- It is impossible to modify settings using the keypad unless the settings lockout pin on the cover is removed
- The test connector remains accessible
- The test button for the earth-fault protection function remains accessible

Characteristics

- Transparent cover for all trip units

Spare battery (for ET6G)

A battery supplies power to the LEDs identifying the tripping causes. The healthiness of the battery to be checked periodically. A test button on the front of the control unit is used to check the battery condition. The battery may be replaced on site when discharged.

Test equipment

Hand-held test kit

The hand-held mini test kit may be used to:

- Check operation of the control unit and the tripping and pole-opening system by sending a signal simulating a short-circuit
- Power source: standard LR6-AA battery

Types of connection are available:

■ Vertical rear connection

The solutions presented are similar in principle for all EasyPact SPS fixed and drawout devices.

Rear connection

Vertical(800 & 1000A)

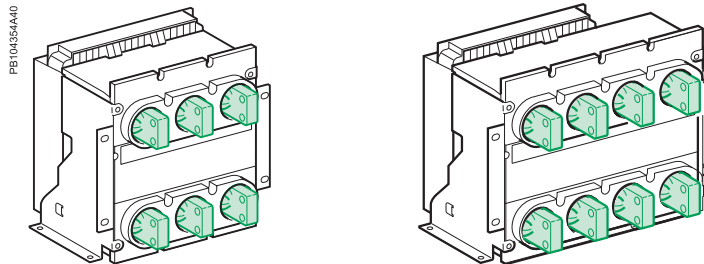

Vertical with spreaders (1250 & 1600A)

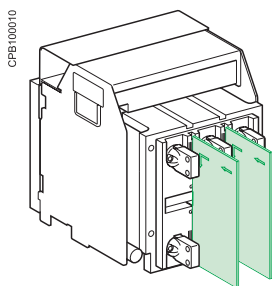
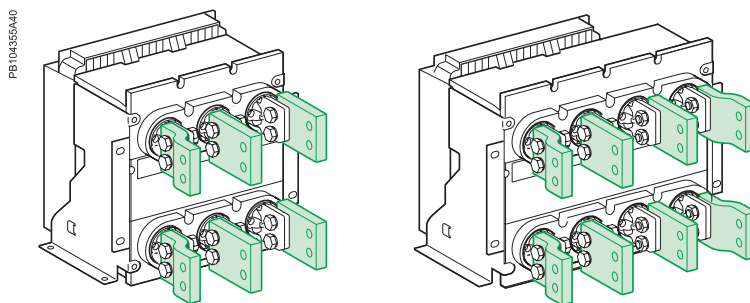

Interphase barriers EIP(option)

These barriers are flexible insulated partitions used to reinforce isolation of connection points in installations with busbars, whether insulated or not. For EasyPact SPS devices, they are installed vertically between rear connection terminals.

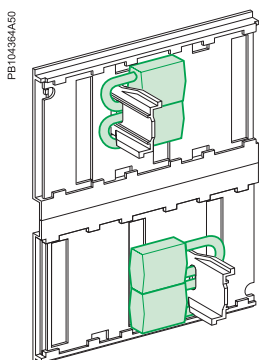



Safety shutters VO(standard)



Mounted on the chassis, the safety shutters automatically block access to the disconnecting contact cluster when the device is in the disconnected or test positions (degree of protection IP 20) When the device is removed from its chassis, no live parts are accessible.

The shutter-locking system is made up of a moving block that can be padlocked (padlock not supplied). The block:

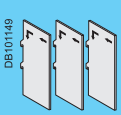
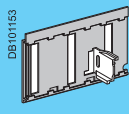
- Prevents connection of the device
- Locks the shutters in the closed position

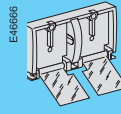
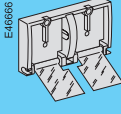
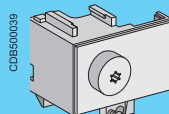
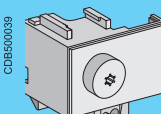
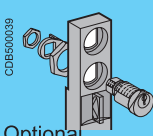
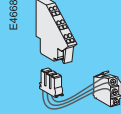
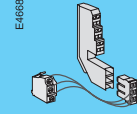
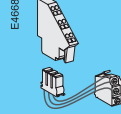
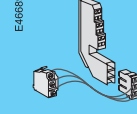
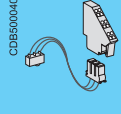
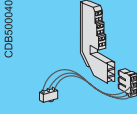
Note: EasyPact SPS circuit breakers can be connected indifferently with bare-copper, tinned-copper and tinned-aluminium conductors, requiring no particular treatment.

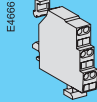
Type of accessory	EasyPact SPS08 to SPS16	
	Fixed breaker Rear connection	Drawout breaker Rear connection
Interphase barriers	 DB101149 Optional	 DB101149 Optional
Safety shutters		 DB101153 Standard
Door interlock		 DB119354 Optional
Pushbutton locking device	 E46666 Optional	 E46666 Optional
OFF position locking	 CDB500039 Optional	 CDB500039 Optional
"Disconnected" position locking		 CDB500039 Optional
ON/OFF indication contacts(OF)	 E46689 2OF Standard	 E46689 2OF Standard
Additional ON/OFF indication contacts(OF)	 E46689 1/2OF Optional	 E46689 1/2OF Optional
"Fault trip" indication contact(SDE)	 CDB500040 Standard	 CDB500040 Standard

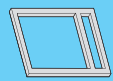
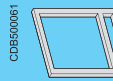
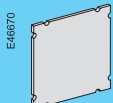
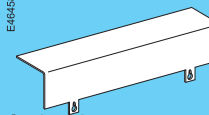
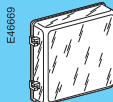
Type of accessory	EasyPact SPS08 to SPS16	
	Fixed breaker Rear connection	Drawout breaker Rear connection
“Connected, disconnected, test position” indication contact(CE,CD,CT)		 E-6661 Optional
“Ready to close” contact(PF)	 E-6438 Optional	 E-6438 Optional
Escutcheon(CDP)	 CDB500061 Standard	 CDB500061 Standard
Escutcheon blanking plate		 E-6670 Optional
Auxiliary terminal shield(CB)		 E-6458 Optional
Transparent cover (IP54)		 E-6669 Optional

- 1 Reset button for mechanical trip indication.
- 2 OFF pushbutton.
- 3 OFF position lock.
- 4 ON pushbutton.
- 5 Contact position indication.
- 6 Spring charge indication.

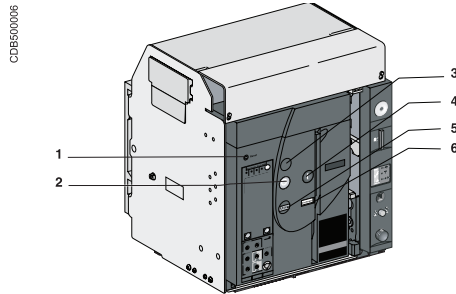

Access to pushbuttons protected by transparent cover.

Pushbutton locking VBP

The transparent cover blocks access to the pushbuttons used to open and close the device.

It is possible to independently lock the opening button and the closing button. The locking device is often combined with a remote operating mechanism.

The pushbuttons may be locked using either:

- Three padlocks (not supplied)
- Lead seal
- Two screws



Pushbutton locking using a padlock.

Device locking in the OFF position by keylocks VSPO

The circuit breaker is locked in the OFF position by physically maintaining the opening pushbutton pressed down:

- Using keylocks (one or two keylocks, optional)

Keys may be removed only when locking is effective (Profaux or Ronis type locks).

The keylocks are available in any of the following configurations:

- One keylock
- One keylock mounted on the device + one identical keylock supplied separately for interlocking with another device

A locking kit (without locks) is available for installation of one or two keylocks (Ronis, Profaux).

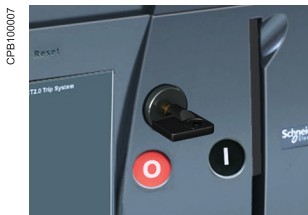

OFF position locking using a keylock.

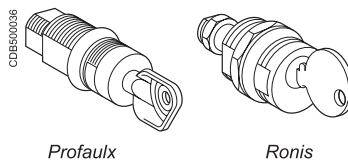

Profaux

Ronis

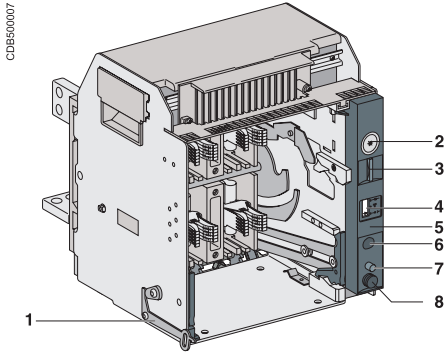

- 1 Door interlock.
- 2 Keylock locking.
- 3 Padlock locking.
- 4 Position indicator.
- 5 Chassis front plate (accessible with cubicle door closed).
- 6 Racking-handle entry.
- 7 Reset Button.
- 8 Racking-handle storage.

“Connected”, “disconnected” and “test” position racking interlock

The “connected”, “disconnected” and “test” positions are shown by an indicator and are mechanically indexed. The exact position is obtained when the racking handle blocks. A release button is used to free it.

“Disconnected” position locking by padlocks or keylocks

VSPD

Mounted on the chassis and accessible with the door closed, these devices lock the circuit breaker in the “disconnected” position in two manners:

- Using padlocks (standard), up to three padlocks (not supplied)
- Using keylocks (optional), one or two different keylocks are available
Profalux and Ronis keylocks are available in different options:
- One keylock
- Two identical key locks - one keylock mounted on the device + one identical keylock supplied separately for interlocking with another device

A locking kit (without locks) is available for installation of one or two keylocks (Ronis, Profalux).

Padlock

1. Circuit breaker in “disconnected” position.

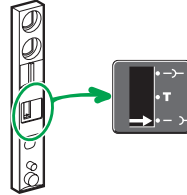

3. Insert the shackle (max. diameter 5 to 8 mm) of the padlock(s).



2. Pull out the tab.

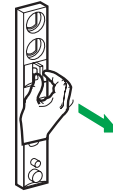

4. The crank cannot be inserted.

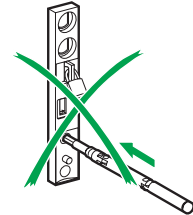

“Disconnected” position locking by padlock.

Keylock

1. Circuit breaker in “disconnected” position.

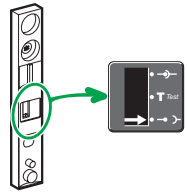

3. Remove the key(s)

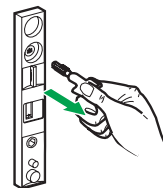

2. Turn the key(s).



4. The crank cannot be inserted.

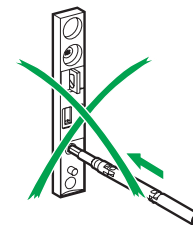

“Disconnected” position locking by keylock.



Door interlock catch VPEC

Mounted on the right or left-hand side of the chassis, this device inhibits opening of the cubicle door when the circuit breaker is in “connected” or “test” position. If the breaker is put in the “connected” position with the door open, the door may be closed without having to disconnect the circuit breaker.

Indication contacts are available:
 ■ in the standard version for relay applications

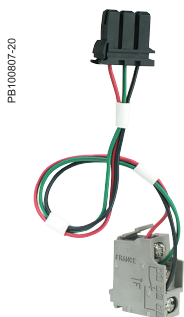

ON/OFF indication contacts (OF) (micro switch type).

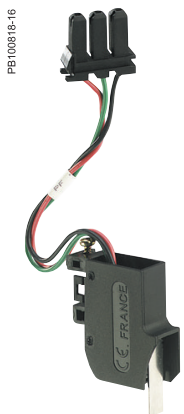

"Fault-trip" indication contact (SDE).

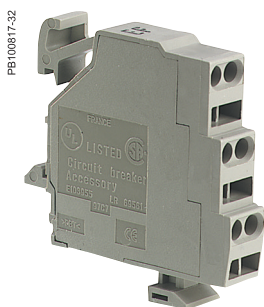

CE, CD and CT "connected/disconnected/test" position carriage switches.

ON/OFF indication contacts OF

Indication contacts indicate the ON or OFF position of the circuit breaker:

- Rotary type changeover contacts directly driven by the mechanism for EasyPact SPS. These contacts trip when the minimum isolation distance between the main circuit-breaker contacts is reached

OF		SPS	
Supplied as standard		2C/O	
Optional contact		1C/O or 2C/O	
Breaking capacity (A)	Standard	Minimum load: 100 mA/24 V	
p.f.: 0.3	V AC	240/380	6
AC12/DC12		480	6
	V DC	24/48	2.5
		125	0.5
		250	0.3

"Fault-trip" indication contact SDE

Circuit-breaker tripping due to a fault is signalled by:

- A red mechanical fault indicator (reset)
- One changeover contact SDE

Following tripping, the mechanical indicator must be reset before the circuit breaker may be closed. One SDE is supplied as standard.

SDE		SPS	
Supplied as standard		1	
Breaking capacity (A)	Standard	Minimum load: 100 mA/24 V	
p.f.: 0.3	V AC	240/380	5
AC12/DC12		480	5
	V DC	24/48	3
		125	0.3
		250	0.15

"Connected", "disconnected" and "test" position carriage switches CE, CD & CT

Three series of optional auxiliary contacts are available for the chassis:

- Changeover contacts to indicate the "connected" position CE
- Changeover contacts to indicate the "disconnected" position CD. This position is indicated when the required clearance for isolation of the power and auxiliary circuits is reached
- Changeover contacts to indicate the "test" position CT. In this position, the power circuits are disconnected and the auxiliary circuits are connected

Additional actuators

A set of additional actuators may be installed on the chassis to change the functions of the carriage switches.

Contacts		SPS	
		CE/CD/CT	
Maximum number	Standard	1 1 1	
Breaking capacity (A)	Standard	Minimum load: 100 mA/24 V	
p.f.: 0.3	V AC	240	8
AC12/DC12		380	8
		480	8
	V DC	24/48	2.5
		125	0.8
		250	0.3

A point-to-point solution for remote operation of EasyPact SPS

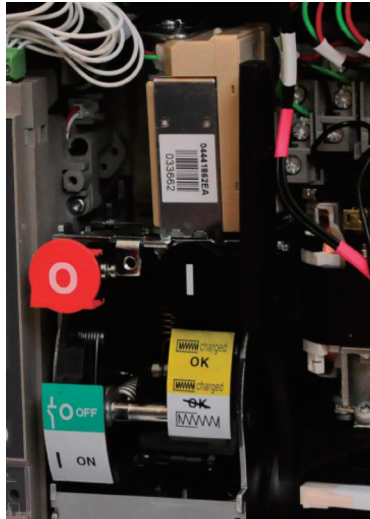

Note: An opening order always takes priority over a closing order.
If opening and closing orders occur simultaneously, the mechanism discharges without any movement of the main contacts. The circuit breaker remains in the open position (OFF).
In the event of maintained opening and closing orders, the standard mechanism provides an anti-pumping function by blocking the main contacts in open position.
Anti-pumping function. After fault tripping or intentional opening using the manual or electrical controls, the closing order must first be discontinued, then reactivated to close the circuit breaker.

The remote ON / OFF function is used to remotely open and close the circuit breaker. It is made up of:

- An electric motor MCH equipped with a "springs charged" limit switch contact CH
- Two voltage releases:
 - A closing release XF
 - An opening release MX

Optionally, other function may be added:

- A "ready to close" contact PF

A remote-operation function is generally combined with:

- Device ON / OFF indication OF
- "Fault-trip" indication SDE

Wiring diagram of a point-to-point remote ON / OFF function

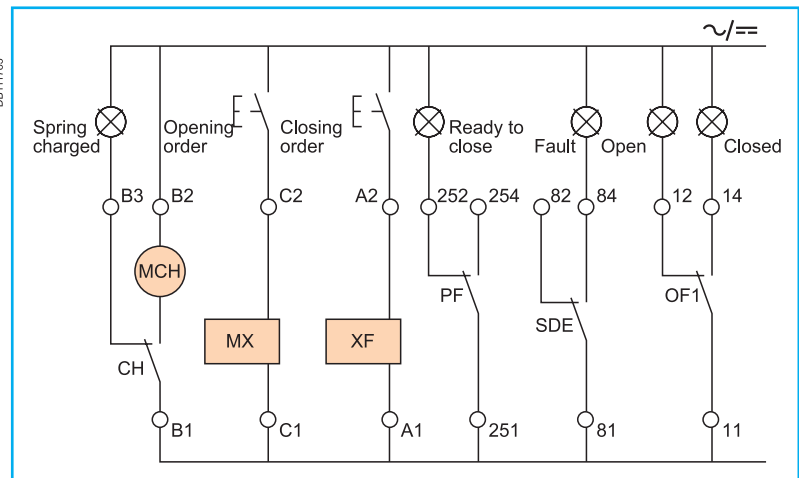

Opening time
Consumption
Motor over
Charging time
Operating frequency
CH contact

Voltage releases XF

Their supply can be maintained

Closing release XF

The XF release remotely closes the circuit breaker when the capacitor is charged.

Opening release MX

The MX release instantaneously opens the circuit breaker in OFF position.

Characteristics

Power supply V AC 50/60 Hz



DE100809-16



MN voltage release.

Instantaneous voltage releases MN

The MN release instantaneously opens the circuit breaker when its supply voltage drops to a value between 35 % and 70 % of its rated voltage. If there is no supply on the release, it is impossible to close the circuit breaker, either manually or electrically. Any attempt to close the circuit breaker has no effect on the main contacts. Circuit breaker closing is enabled again when the supply voltage of the release returns to 85% of its rated value.

Characteristics

Power supply	V AC 50/60 Hz	24 - 48 - 100/130 - 200/250 - 380/480
	V DC	24/30 - 48/60 - 100/130 - 200/250
Operating threshold	Opening	0.35 to 0.7 Un
	Closing	0.85 Un
Consumption (VA or W)		Pick-up: 200 (200 ms) Hold: 4.5
MN consumption with delay unit (VA or W)		Pick-up: 200 (200 ms) Hold: 4.5
Circuit-breaker response time at Un		40 ms ±5

056422N



MN delay unit.

MN delay units

To eliminate circuit-breaker nuisance tripping during short voltage dips, operation of the MN release can be delayed. This function is achieved by adding an external delay unit in the MN voltage-release circuit. Two versions are available, adjustable and non-adjustable.

Characteristics

Power supply	Non-adjustable	100/130 - 200/250
V AC 50-60 Hz /DC	Adjustable	48/60 - 100/130 - 200/250 - 380/480
Operating threshold	Opening	0.35 to 0.7 Un
	Closing	0.85 Un
Delay unit consumption		Pick-up: 200 (200 ms) Hold: 4.5
Circuit-breaker response time at Un	Non-adjustable	0.25 s
	Adjustable	0.5 s - 0.9 s - 1.5 s - 3 s

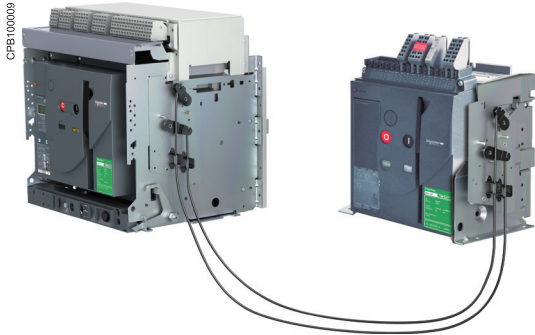

Interlocking of two EasyPact circuit breakers using cable.

Interlocking of two EasyPact SPS/MVS devices using cables

For cable interlocking, the circuit breakers may be mounted one above the other or side-by-side. The interlocked devices may be fixed or drawout, three-pole or four-pole, and have different ratings.

Interlocking between two devices

This function requires:

- An adaptation fixture on the right side of each device
- A set of cables with no-slip adjustments
- The use of a mechanical operation counter CDM is compulsory

The maximum distance between the fixing planes (vertical or horizontal) is 2000 mm.

Installation

The adaptation fixtures, sets of cables and circuit breakers or switch-disconnectors are supplied separately, ready for assembly by the customer.

Installation conditions for cable interlocking systems:

- Cable length: 2.5 m
- Radius of curvature: 100 mm
- Maximum number of curves: 3

Possible combinations of "Normal" and "Replacement" source circuit breakers		
"Normal N"	"Replacement" R	
SPS08 to SPS16 Ratings 800...1600A	SPS08 to SPS16 ■	MVS08 to MVS40 ■
MVS08 to MVS40 Ratings 800...4000A	■	■

All combinations of two EasyPact SPS and EasyPact MVS devices are possible, whatever the rating or size of the devices.

PE104740

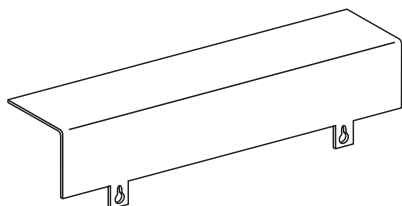

Auxiliary terminal shield CB

Optional equipment mounted on the chassis, the shield prevents access to the terminal block of the electrical auxiliaries.

PE10432A32

DE101173

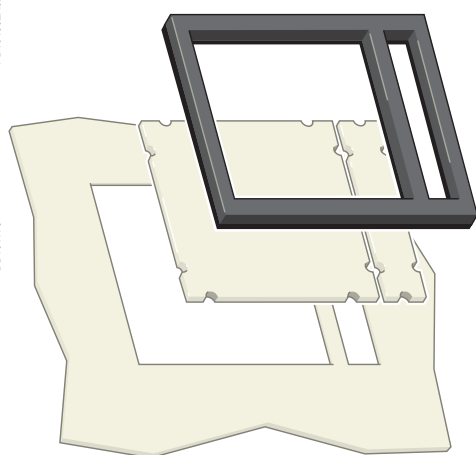

Escutcheon CDP

Standard equipment mounted on the door of the cubicle, the escutcheon increases the degree of protection to IP 40 (circuit breaker installed free standing: IP30) . It is available in fixed and drawout versions.

Blanking plate for escutcheon OP

Used with the escutcheon, this option closes off the door cut-out of a cubicle not yet equipped with a device. It adapts to drawout devices.

Escutcheon CDP with blanking plate.

PE100776-42

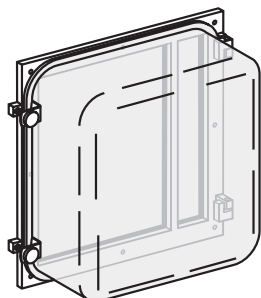

Transparent cover for escutcheon CP

Optional equipment mounted on the escutcheon, the cover is hinged and secured by a screw. It increases the degree of protection to IP54, IK10. It adapts to drawout devices.

Transparent cover CP for escutcheon.

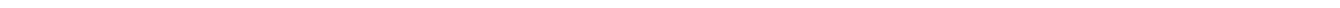

Installation recommendations



<i>Functions and characteristics</i>	A-1
Operating conditions	B-2
Installation in switchboard	B-3
Door interlock catch	B-5
Control wiring	B-6
Power connection	B-7
Recommended busbars drilling	B-9
Busbar sizing	B-10
Temperature derating	
Power dissipation	B-11
<i>Dimensions and connection</i>	<i>C-1</i>
<i>Electrical diagrams</i>	<i>D-1</i>
<i>Additional characteristics</i>	<i>E-1</i>
<i>Catalogue numbers and order form</i>	<i>F-1</i>

EasyPact SPS circuit breakers have been tested for operation in industrial atmospheres. It is recommended that the equipment be cooled or heated to the proper operating temperature and kept free of excessive vibration and dust.

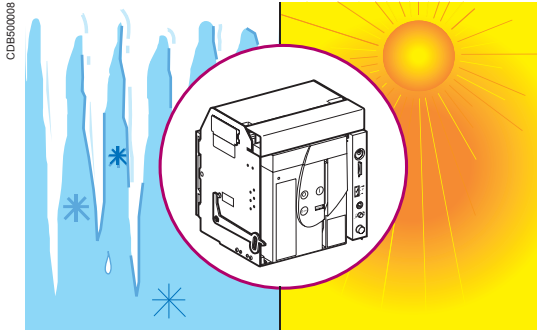

Ambient temperature

EasyPact SPS devices can operate under the following temperature conditions:

- The electrical and mechanical characteristics are stipulated for an ambient temperature of -5°C to +60°C
- Circuit-breaker closing is guaranteed down to -35°C

Storage conditions are as follows:

- -35 to +85°C for a Easycompact SPS device without its control unit
- -25°C to +85°C for the control unit

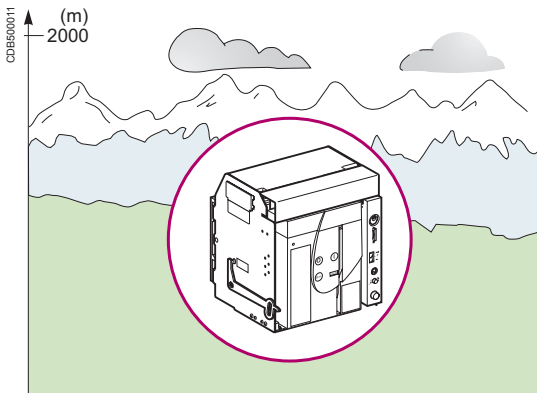

Altitude

At altitudes higher than 2000 metres, the modifications in the ambient air (electrical resistance, cooling capacity) lower the following characteristics as follows:

Altitude (m)	2000	3000
Impulse withstand voltage uimp (kV)	12	11
Rated insulation voltage (Ui)	1000	900
Maximum rated operational voltage 50/60 Hz Ue (V)	440	440
Rated current 40°C	1 x In	0.99 x In

Intermediate values may be obtained by interpolation.

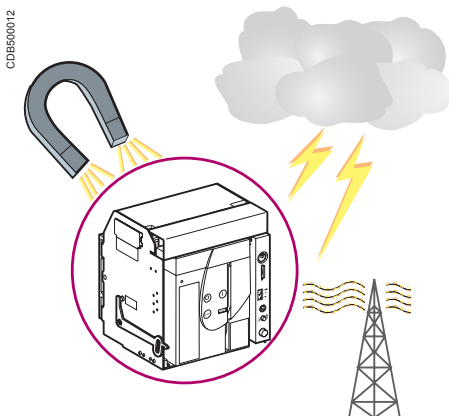

Electromagnetic disturbances

EasyPact SPS devices are protected against:

- Overvoltages caused by devices that generate electromagnetic disturbances
- Overvoltages caused by atmospheric disturbances or by a distribution-system outage (e.g. failure of a lighting system)
- Devices emitting radio waves (radios, walkie-talkies, radar, etc.)
- Electrostatic discharges produced by users

EasyPact SPS devices have successfully passed the electromagnetic-compatibility tests (EMC) defined by the following international standards:

- IEC 60947-2, appendix F

The above tests guarantee that:

- No nuisance tripping occurs
- Tripping times are respected

Installation in switchboard

Possible positions

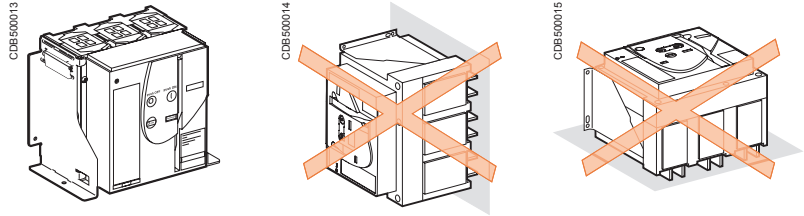

Power supply

EasyPact SPS devices can be supplied either from the top or from the bottom without reduction in performance, in order to facilitate connection when installed in a switchboard.

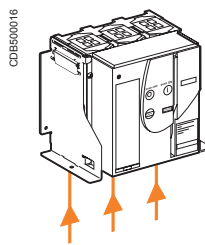

Mounting the circuit-breaker

It is important to distribute the weight of the device uniformly over a rigid mounting surface such as rails or a base plate.

This mounting plane should be perfectly flat (tolerance on support flatness: 2 mm). This eliminates any risk of deformation which could interfere with correct operation of the circuit breaker.

EasyPact devices can also be mounted on a vertical plane using the special brackets.

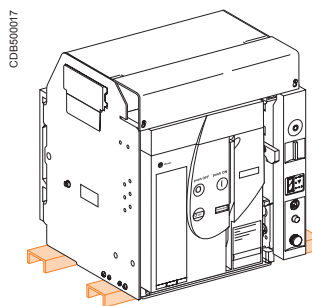

Mounting on rails.

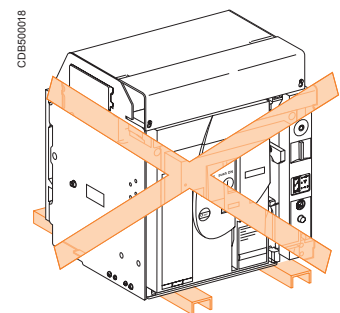

Partitions

Sufficient openings must be provided in partitions to ensure good air circulation around the circuit breaker; Any partition between upstream and downstream connections of the device must be made of nonmagnetic material.

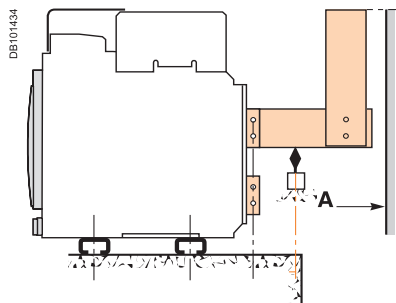

A : Non magnetic material.



Busbars

The mechanical connection must exclude the possibility of formation of a magnetic loop around a conductor.

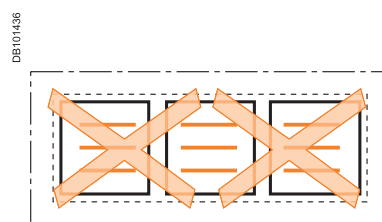
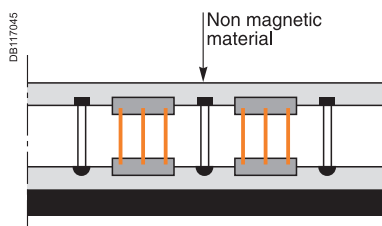

For live busbars installed immediately above the circuit breaker (respecting the 100 mm safety clearance), the distance between bars must be 65 mm minimum

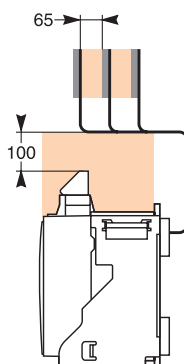

Interphase barrier

If the insulation distance between phases is not sufficient (≤ 14 mm), it is advised to install phase barriers (taking into account the safety clearances).

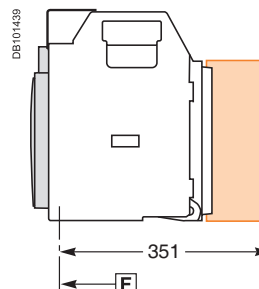
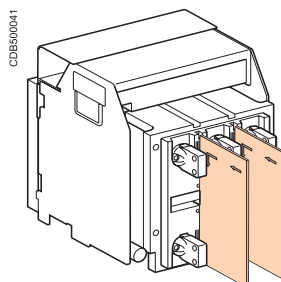

Door interlock catch

Door interlock VPEC

Mounted on the right or left-hand side of the chassis, this device inhibits opening of the cubicle door when the circuit breaker is in "connected" or "test" position. If the breaker is put in the "connected" position with the door open, the door may be closed without having to disconnect the circuit breaker.

CD6600034

Dimensions (mm)

Type	(1)	(2)
SPS08-16 (3P)	135	168
SPS08-16(4P)	205	168

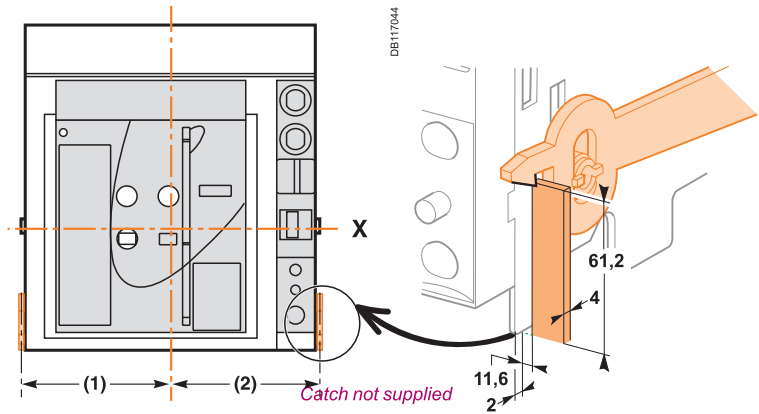

Breaker in "connected" or "test" position
Door cannot be opened

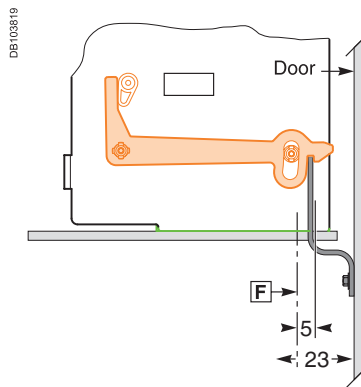

Breaker in "disconnected" position
Door can be opened

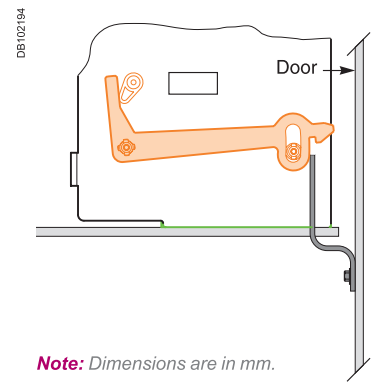

Note: The door interlock can either be mounted on the right side or the left side of the breaker.

F: Datum.

Wiring of voltage releases

During pick-up, the power consumed is approximately 150 to 200 VA. For low control voltages (24, 48 V), maximum cable lengths are imposed by the voltage and the cross-sectional area of cables.

Recommended maximum cable lengths (meter).

		24 V		48 V	
		2,5 mm ²	1,5 mm ²	2,5 mm ²	1,5 mm ²
MN	U source 100 %	58	35	280	165
	U source 85 %	16	10	75	45
MX-XF	U source 100 %	115	70	550	330
	U source 85 %	75	44	350	210

Note: The indicated length is that of each of the two wires.

Power connection

Cables connections

If cables are used for the power connections, make sure that they do not apply excessive mechanical forces to the circuit breaker terminals.

For this, make the connections as follows:

- Extend the circuit breaker terminals using short bars designed and installed according to the recommendations for bar-type power connections:
 - For a single cable, use solution **B** opposite
 - For multiple cables, use solution **C** opposite
- In all cases, follow the general rules for connections to busbars:
 - Position the cable lugs before inserting the bolts
 - The cables should firmly secured to the framework **E**

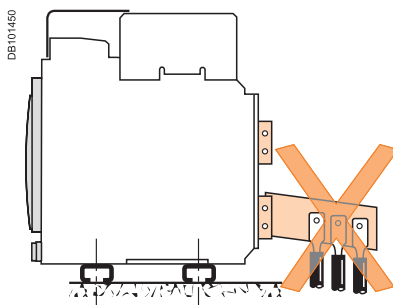
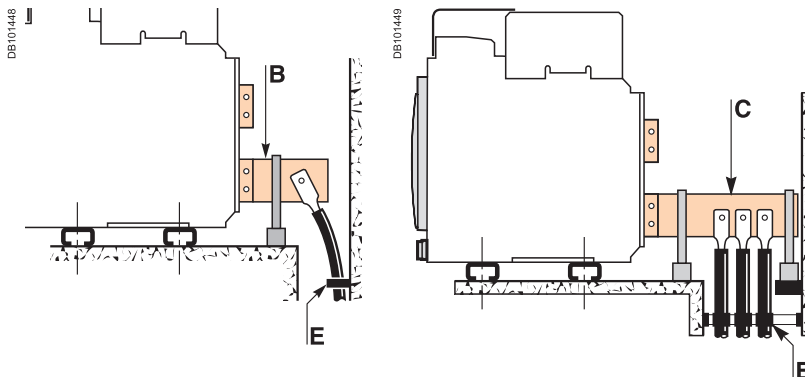

Busbars connections

The busbars should be suitably adjusted to ensure that the connection points are positioned on the terminals before the bolts are inserted **B**

The connections are held by the support which is solidly fixed to the framework of the switchboard, such that the circuit breaker terminals do not have to support its weight **C**. (This support should be placed close to the terminals).

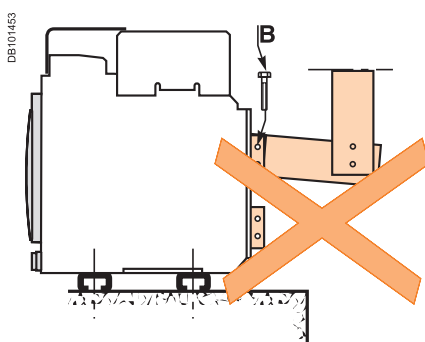
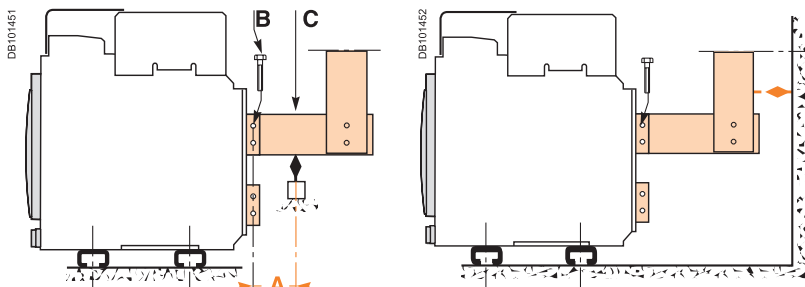

Electrodynamic stresses

The first busbar support or spacer shall be situated within a maximum distance from the connection point of the breaker (see table below). This distance must be respected so that the connection can withstand the electrodynamic stresses between phases in the event of a short circuit.

Maximum distance A between busbar to circuit breaker connection and the first busbar support or spacer with respect to the value of the prospective short-circuit current.

Isc (kA)	30	50
Distance A (mm)	350	300

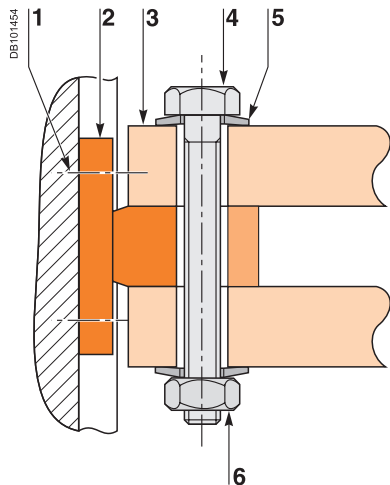

- 1 Terminal screw factory-tightened to 16 Nm.
- 2 Breaker terminal.
- 3 Busbar.
- 4 Bolt.
- 5 Washer.
- 6 Nut.

Clamping

Correct clamping of busbars depends amongst other things, on the tightening torques used for the nuts and bolts. Over-tightening may have the same consequences as under-tightening.

For connecting busbars (Cu ETP-NFA51-100) to the circuit breaker, the tightening torques to be used are shown in the table below.

These values are for use with copper busbars and steel nuts and bolts, class 8.8. The same torques can be used with AGS-T52 quality aluminium bars (French standard NFA 02-104 or American National Standard H-35-1).

Examples

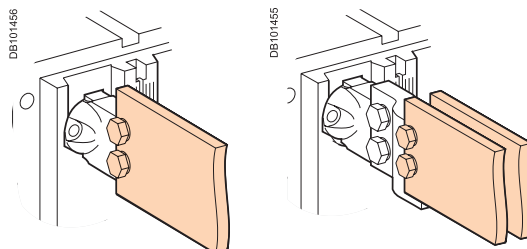

Tightening torques			
Ø (mm) Nominal	Ø (mm) Drilling	Tightening torques (Nm) with grower or flat washers	Tightening torques (Nm) with contact or corrugatec washers
10	11	37.5	50

Busbar drilling

Examples

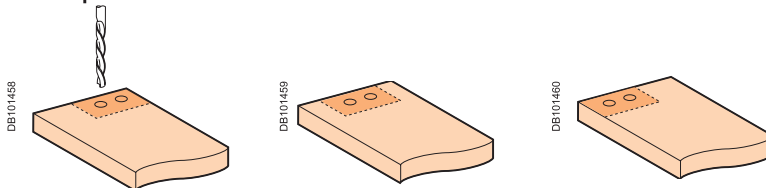

Isolation distance

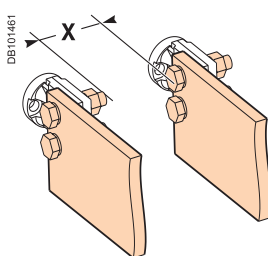

Dimensions (mm)

Ui	X min
600 V	8mm
1000V	14mm

When bending busbars maintain the radius indicated below (a smaller radius would cause cracks).

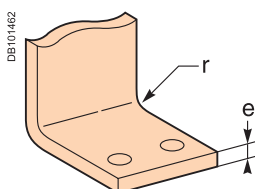

Dimensions (mm)

e	Radius of curvature r	
	Min	Recommended
5	5	7.5
10	15	18 to 20

Recommended busbars drilling

EasyPact SPS08 to SPS16

Rear connection

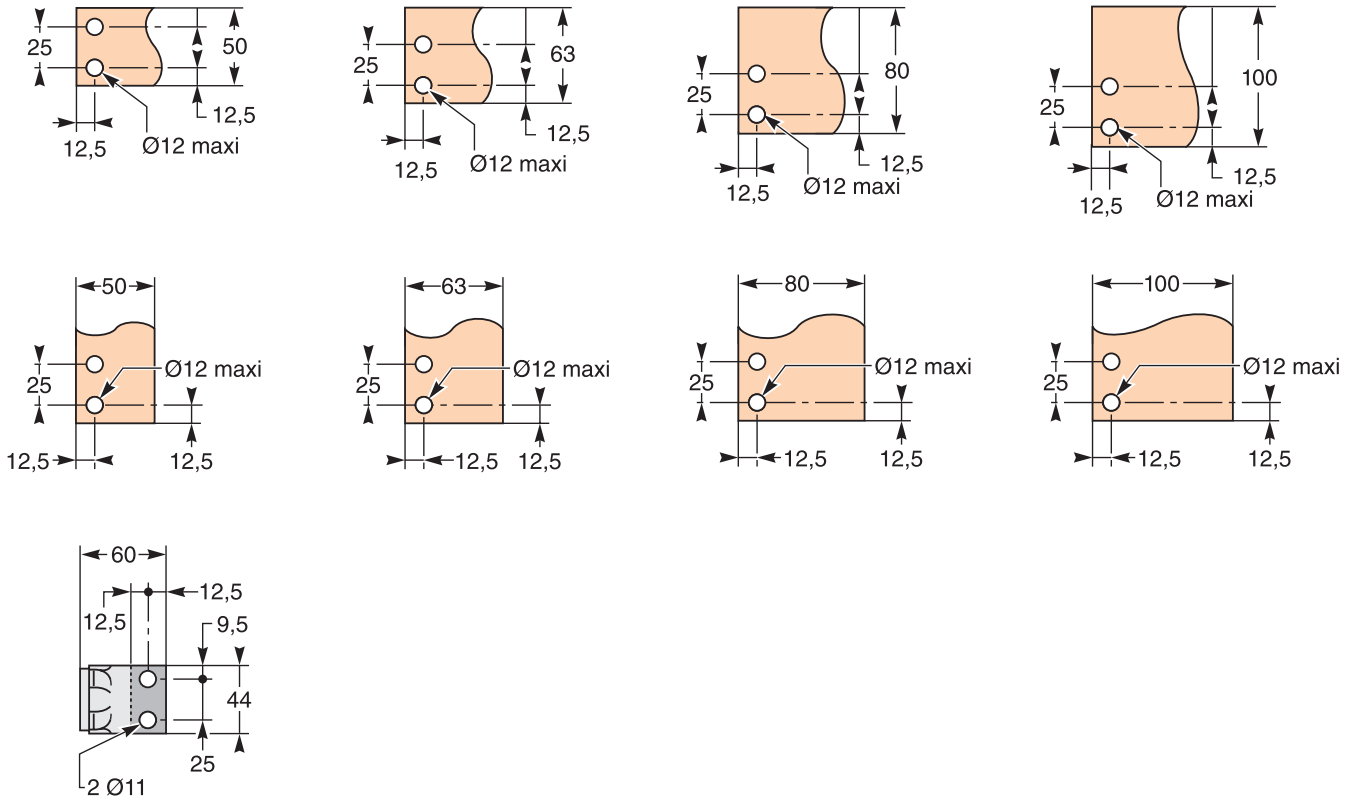

Rear connection with spacers (SPS12 / SPS16)

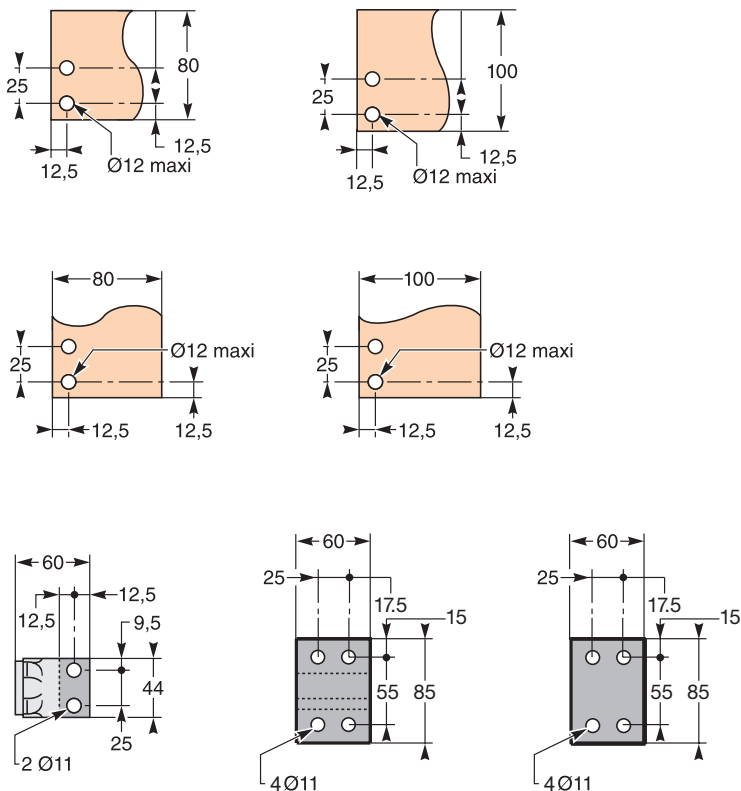

Basis of tables:

- Maximum permissible busbars temperature: 100°C
- T_i : temperature around the circuit breaker and its connection
- Busbar material is unpainted Copper/ Aluminium

Rear vertical connection

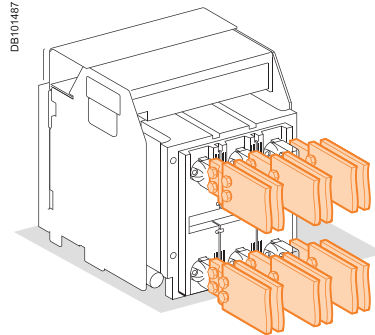

Unpainted Copper (Vertical connection)			
EasyPact	Maximum service current	T_i : 40°C No. of 5 mm thick bars	T_i : 50°C No. of 5 mm thick bars
SPS08	800	2b.50 x 5	2b.50 x 5
SPS10	1000	2b.50 x 5	2b.50 x 5
SPS12	1250	2b.63 x 5	3b.50 x 5
SPS16	1600	3b.63 x 5	3b.63 x 5

Unpainted Aluminium (Vertical connection)		
EasyPact	Maximum service current	T_i : 50°C
SPS08	800	1b.80 x 10
SPS10	1000	1b.100 x 10
SPS12	1250	2b.100 x 6
SPS16	1600	2b 80 x 10

Example

Conditions:

- Drawout version
- Vertical busbars
- T_i : 50°C
- Service current: 1600 A

Solution:

For $T_i = 50^\circ\text{C}$, use an SPS16 which can be connected with 3 bars-63 x 5 mm Copper (or) 2 bars-80x10mm Aluminium

Note: The values indicated in these tables have been extrapolated from test data and theoretical calculations. These tables are only intended as a guide and cannot replace industrial experience or a temperature rise test.

Temperature derating Power dissipation

Temperature derating

The table below indicates the maximum current rating, for each connection type, as a function of T_i around the circuit breaker and the busbars.

For T_i greater than 60°C, consult us.

T_i : temperature around the circuit breaker and its connection.

Version	Drawout					Fixed				
Connection	Rear vertical					Rear vertical				
Temp. T_i	40 °C	45 °C	50 °C	55 °C	60 °C	40 °C	45 °C	50 °C	55 °C	60 °C
SPS (50kA)										
SPS08F	800					800				
SPS10F	1000					1000				
SPS12F	1250			1225		1250				
SPS16F	1600		1560		1510	1600				

Power dissipation

Total power dissipation is the value measured at I_N , 50/60 Hz, for a 3 pole or 4 pole breaker (values above the power $P = 3RI^2$). The resistance between input / output is the value measured per pole (cold state).

Type	Draw-out	Fixed
50kA	Input/output resistance (μohm)	Input/output resistance (μohm)
SPS08F	38	26
SPS10F	38	26
SPS12F	38	26
SPS16F	36	26

Dimensions and connection



<i>Functions and characteristics</i>	A-1
<i>Installation recommendations</i>	B-1
SPS08 to SPS16 circuit breakers	C-2
Fixed 3/4-poles device	C-2
Drawout 3/4-poles device	C-4
External modules	C-6
<i>Electrical diagrams</i>	D-1
<i>Additional characteristics</i>	E-1
<i>Catalogue numbers and order form</i>	F-1

Dimensions

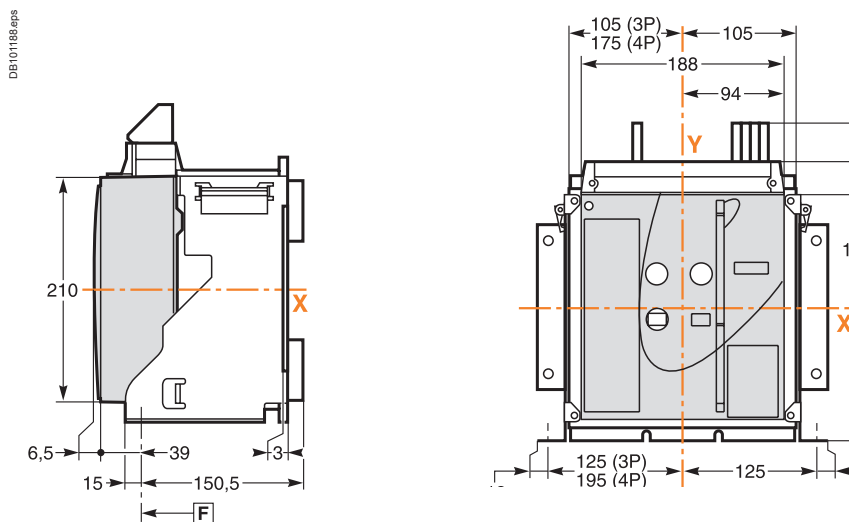

Bottom mounting (on base plate or rails)

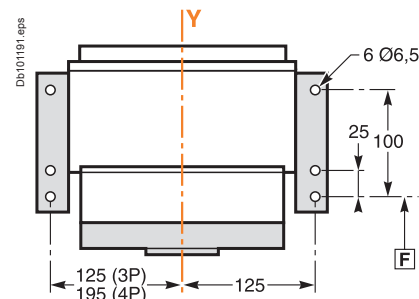
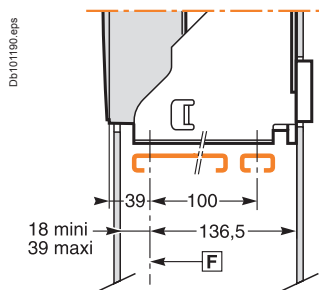

Rear mounting detail (on upright or backplate)

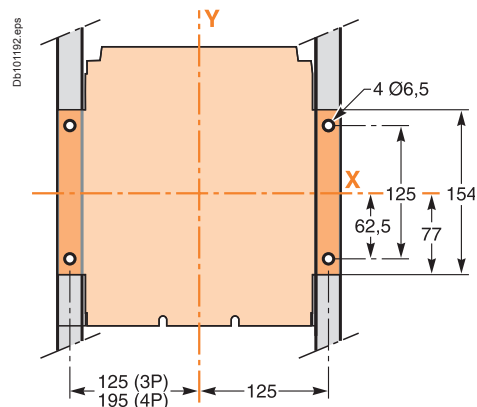

Safety clearances

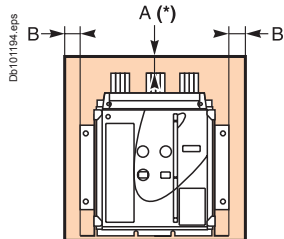
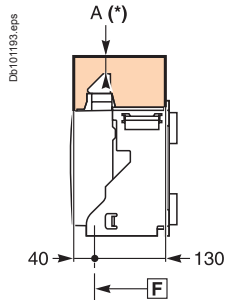

Door cutout

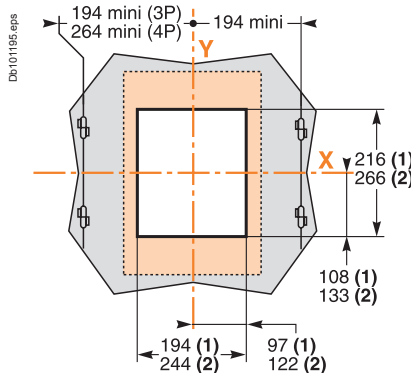

Rear panel cutout

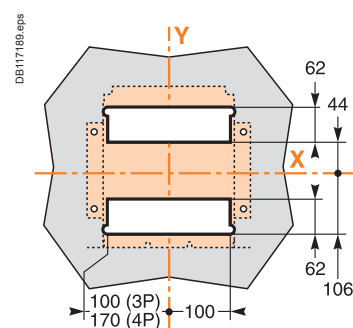

For voltages < 690 V

	Parts		
	Insulated	Metal	Energised
A	0	0	100
B	0	0	60

F: datum.

- (1) Without escutcheon.
- (2) With escutcheon.

Note: X and Y are the symmetry planes for a 3-pole device.
A(*) An overhead clearance of 50 mm is required to remove the arc chutes.
An overhead clearance of 20 mm is required to remove the terminal block.

Connections

Vertical rear connection SPS08F/SPS10F

Detail

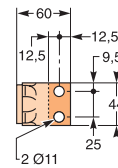
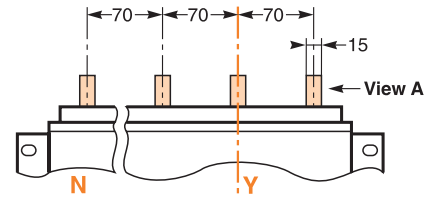
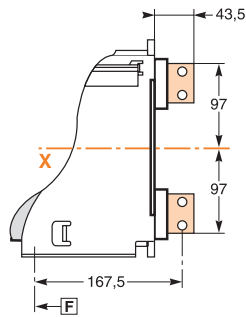
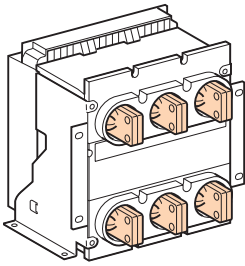

Vertical rear connection SPS12F/SPS16F(3P)

Detail

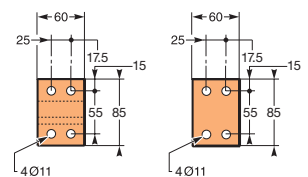
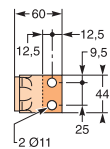
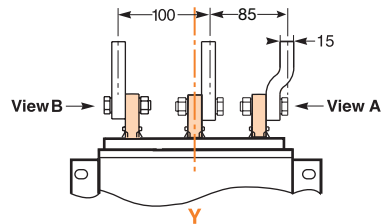
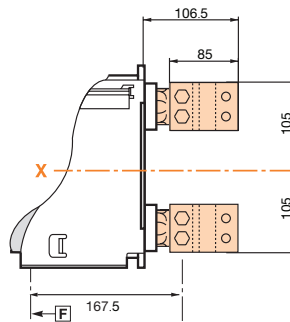
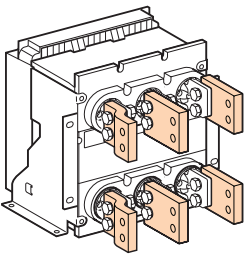

View A detail.

View B detail.

Vertical rear connection SPS12F/SPS16F (4P)

Detail

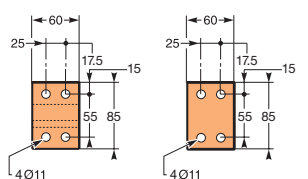
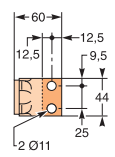
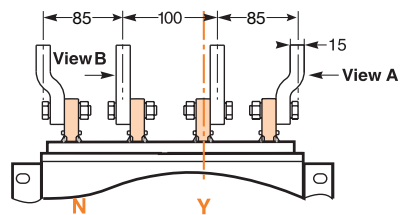
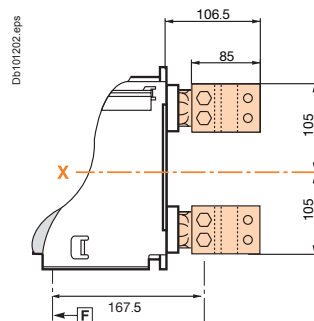
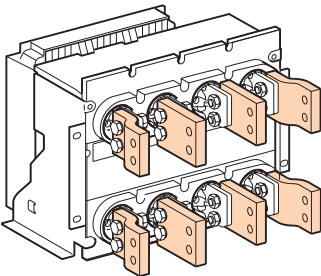

View A detail.

View B detail.

Note: recommended connection screws: **M10** class 8.8.
Tightening torque: **50 Nm** with contact washer.

Dimensions

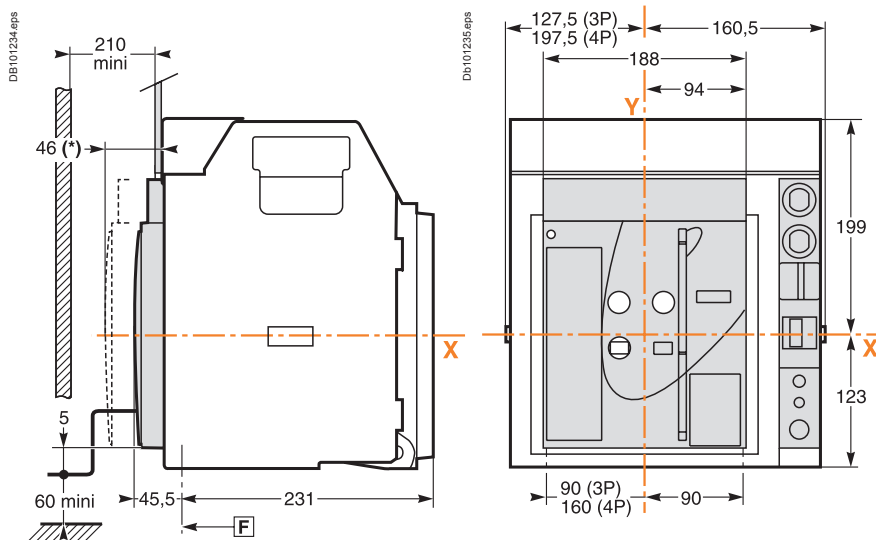

(*): Disconnected position.

Bottom mounting (on base plate or rails)

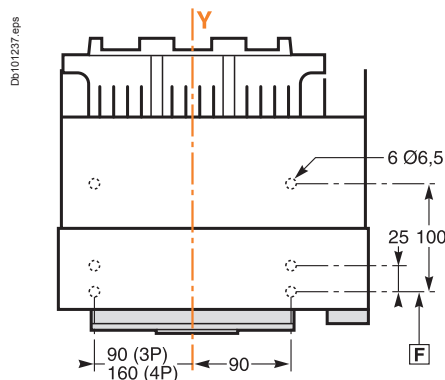
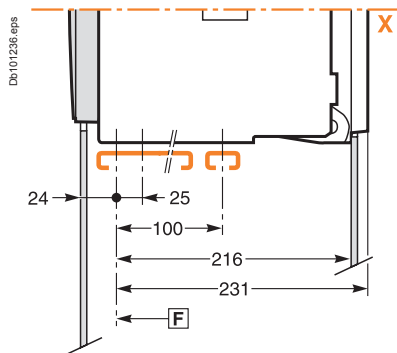

Rear mounting detail (on upright or backplate)

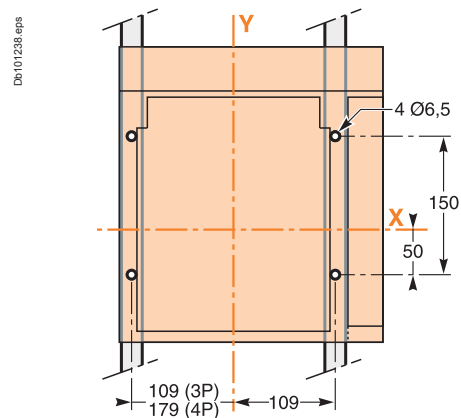

Safety clearances

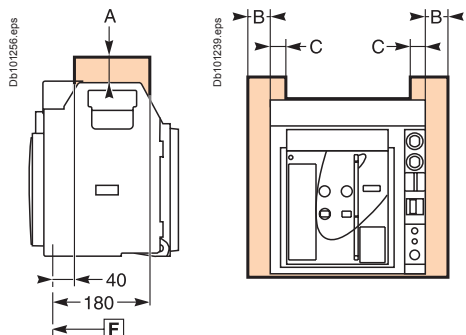

Door cutout

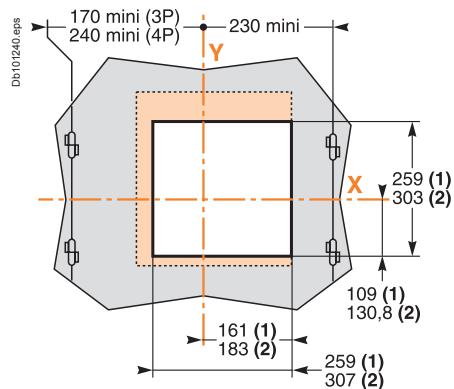

Rear panel cutout

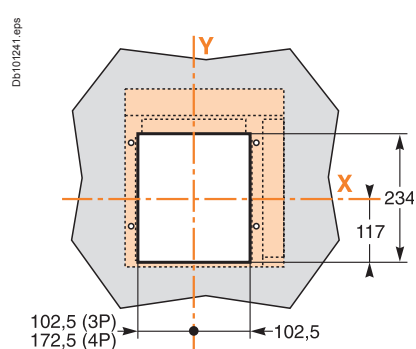

For voltages ≤ 690 V

	Parts		
	Insulated	Metal	Energised
A	0	0	30
B	10	10	60
C	0	0	30

F: datum.

(1) Without escutcheon.

(2) With escutcheon.

Note: X and Y are the symmetry planes for a 3-pole device.

Connections

Vertical rear connection SPS08F/SPS10F

Detail

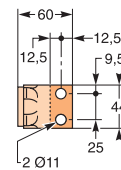
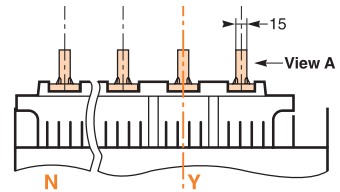
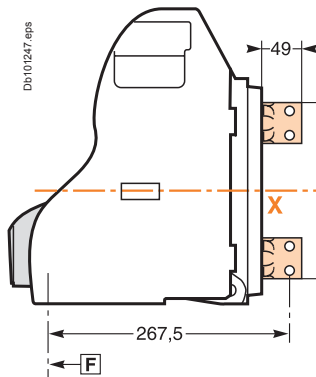
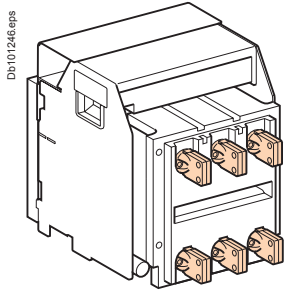

Vertical rear connection SPS12F/SPS16F(3P)

Detail

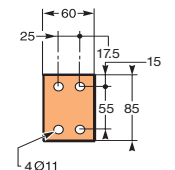
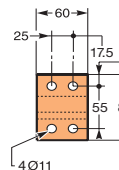
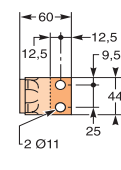
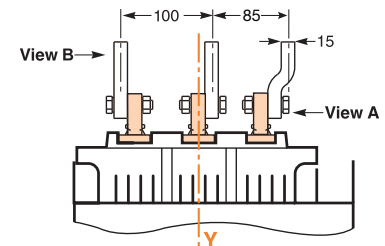
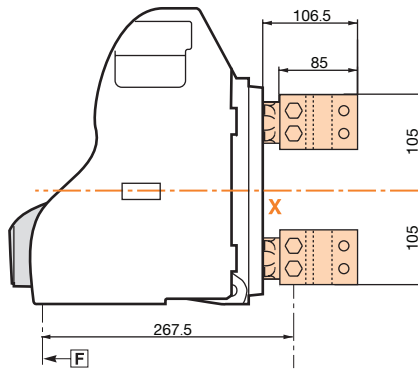
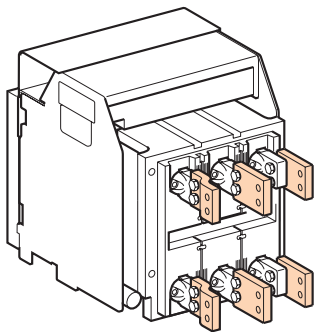

View A detail.

View B detail.

Vertical rear connection SPS12F/SPS16F(4P)

Detail

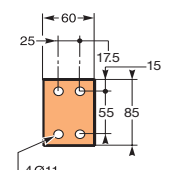
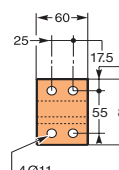
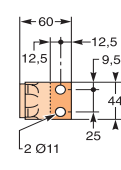
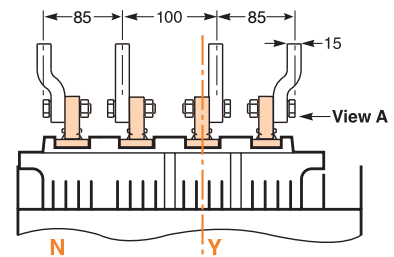
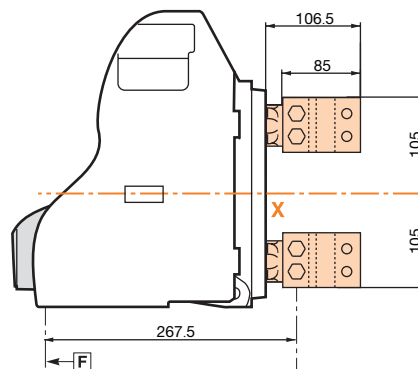
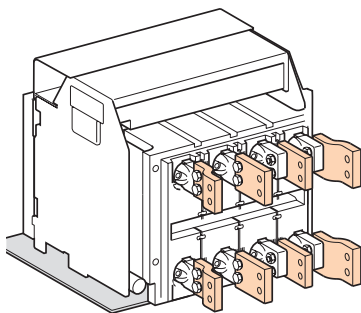

View A detail.

View B detail.

Note: recommended connection screws: **M10** class 8.8.
Tightening torque: **50 Nm** with contact washer.

Connection of auxiliary wiring to terminal block

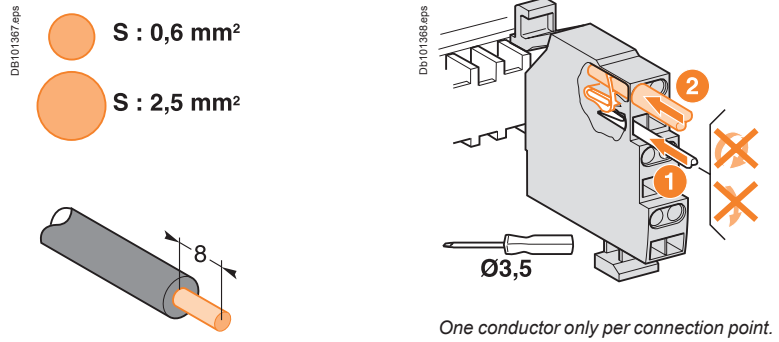

Delay unit for MN release

Mounting

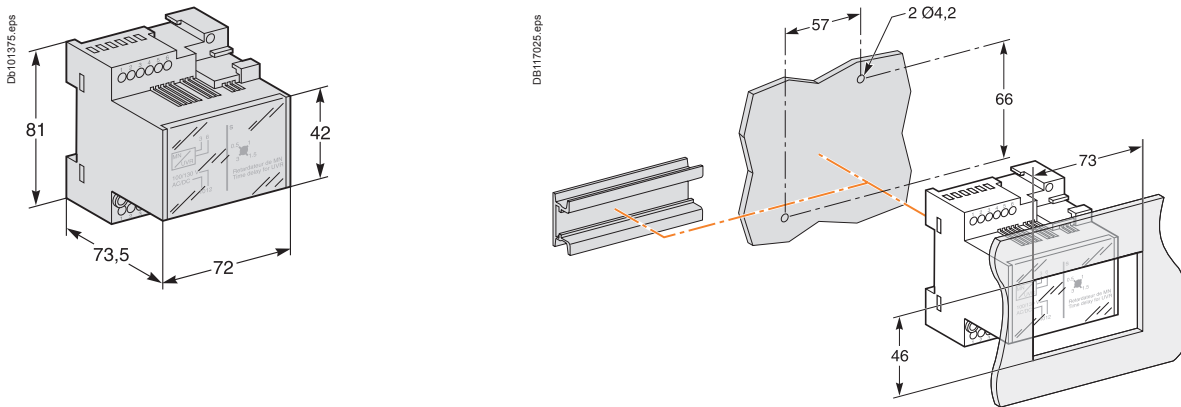

External sensor for external neutral

Dimensions

400/1600 A (SPS08 to SPS16)

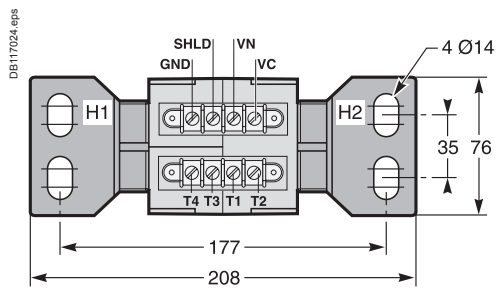

High: 162 mm.

Installation

400/2000 A (SPS08 to SPS16)

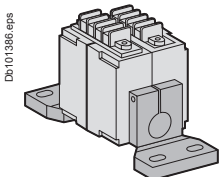



Electrical diagrams



<i>Functions and characteristics</i>	A-1
<i>Installation recommendations</i>	B-1
<i>Dimensions and connection</i>	C-1
EasyPact SPS08 to SPS16	D-2
Fixed and drawout devices	D-2
EasyPact SPS	D-4
Earth-fault protection/Neutral protection	D-4
Zone Selective Interlocking	D-5
<i>Additional characteristics</i>	E-1
<i>Catalogue numbers and order form</i>	F-1

The diagram is shown with circuits de-energised, all devices open, connected and charged and relays in normal position.

Power

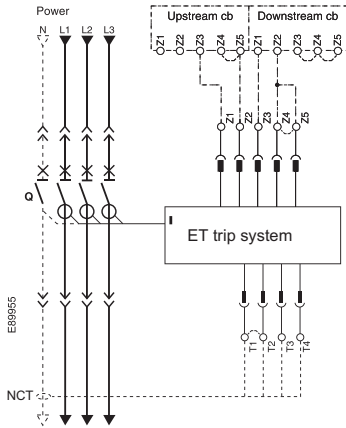

Note: Z1...Z5 & T1...T4 are available only in ET6G trip system

Remote operation

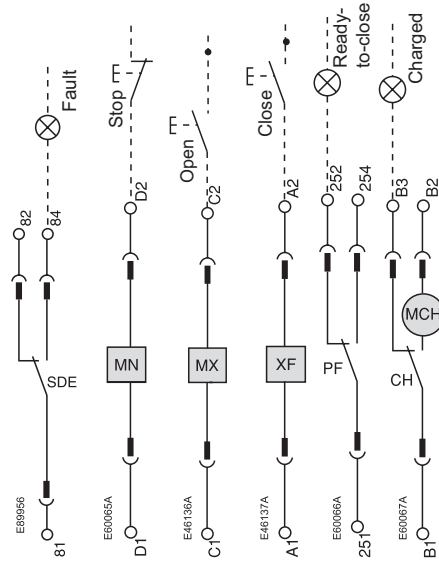

ET trip system

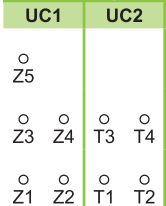

Remote operation

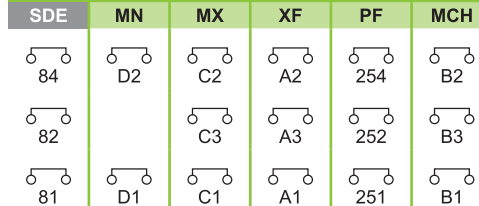

ET/ETA/ETV trip system

UC1 :
 Z1-Z5 zone selective interlocking
 Z1=ZSI OUT SOURCE
 Z2=ZSI OUT ; Z3 = ZSI IN SOURCE
 Z4 =ZSI IN ST (short time)
 Z5 =ZSI IN GF (earth fault)

UC2 :
 T1, T2, T3, T4=external neutral

Remote operation

SDE: Fault-trip indication contact (supplied as standard)
MN: Undervoltage release
MX: Shunt release (standard for Electrical breaker)
XF: Closing release (standard for Electrical breaker)
PF: "Ready to close" contact
MCH: Gear motor (standard for Electrical breaker)

E47477

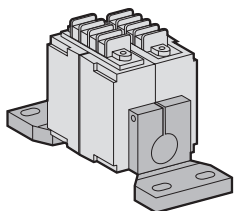

External sensor (CT).

External sensors (Neutral CT)

External sensor for earth-fault protection
 The sensors, used with the 3P circuit breakers, are installed on the neutral conductor for:

- Residual type earth-fault protection(ET 6G trip system)

The rating of the sensor (CT) must be compatible with the rating of the circuit breaker:

- SPS08 to SPS16 : CT 400/1600A;

Indication contacts

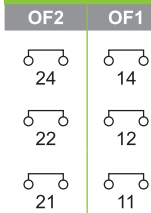
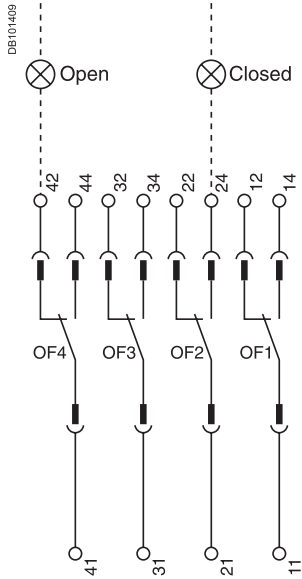

Standard

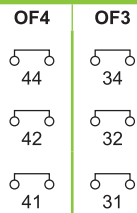

Optional

Chassis contacts

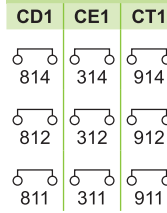
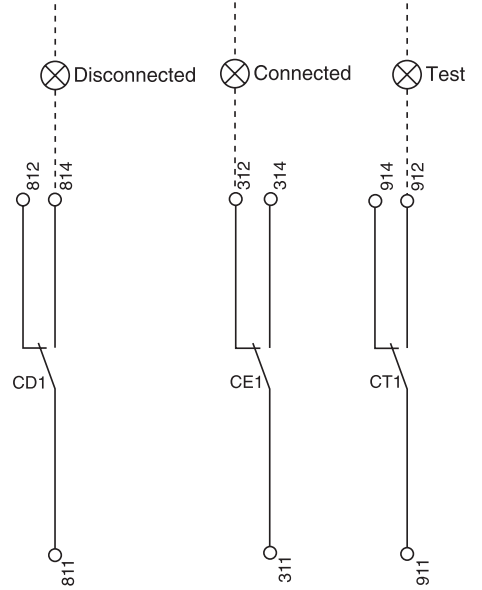

Optional

Indication contacts

OF2	Standard
OF1	ON/OFF Indication contacts

OF4	Optional
OF3	ON/OFF Indication contacts

Chassis contacts

CD1 Disconnected Position Contact	CE1 Connected Position Contact	CT1 Test Position Contact
--	---	--

Key:

Drawout device only

SDE, OF1, OF2 supplied as standard

Interconnected connections
(only one wire per connection point)

External sensor (CT) for residual earth-fault protection

Connection of current-transformer secondary circuit for external neutral

EasyPact SPS equipped with a ET6G:

- Shielded cable with 2 twisted pairs
- T1 twisted with T2
- Maximum length 4 meters
- Cable cross-sectional area 0.4 to 1.5 mm²
- Recommended cable: Belden 9552 or equivalent

For proper wiring of neutral CT, refer to instruction Bulletin 48041-082-03 shipped with it.

Do not remove factory-installed jumper between T1 and T2 unless neutral CT is connected.

If supply is via the top, follow the schematics.

If supply is via the bottom, control wiring is identical; for the power wiring, H1 is connected to the source side, H2 to the load side.

For four-pole versions, for residual earth-fault protection, the current transformer for the external neutral is not necessary.

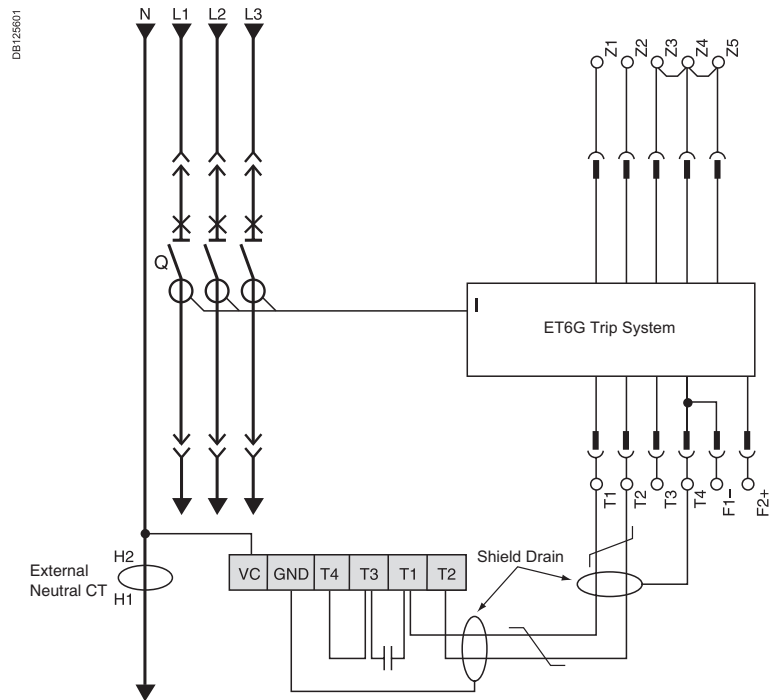

Neutral protection

- Three pole circuit breaker:
 - Neutral protection is impossible
- Four pole circuit breaker:
 - The current transformer for external neutral is not necessary

Zone selective interlocking

Zone-selective interlocking is used to reduce the electrodynamic forces exerted on the installation by shortening the time required to clear faults, while maintaining time discrimination between the various devices.

A pilot wire interconnects a number of circuit breakers equipped with ET range of trip system, as illustrated in the diagram above.

The control unit detecting a fault sends a signal upstream and checks for a signal arriving from downstream. If there is a signal from downstream, the circuit breaker remains closed for the full duration of its tripping delay. If there is no signal from downstream, the circuit breaker opens immediately, regardless of the tripping-delay setting.

Fault 1.

Only circuit breaker A detects the fault. Because it receives no signal from downstream, it opens immediately, regardless of its tripping delay set to 0.3.

Fault 2.

Circuit breakers A and B detect the fault. Circuit breaker A receives a signal from B and remains closed for the full duration of its tripping delay set to 0.3. Circuit breaker B does not receive a signal from downstream and opens immediately, in spite of its tripping delay set to 0.2.

Wiring

- Maximum impedance: 2.7 Ω / 300 m
- Capacity of connectors: 0.4 to 2.5 mm²
- Wires: single or multicore
- Maximum length: 3000 m
- Limits to device interconnection:
 - The common ZSI - OUT (Z1) and the output ZSI - OUT (Z2) can be connected to a maximum of 10 upstream device
 - A maximum of 100 downstream devices may be connected to the common ZSI - IN (Z3) and to an input ZSI - IN CR (Z4 or GF (Z5)

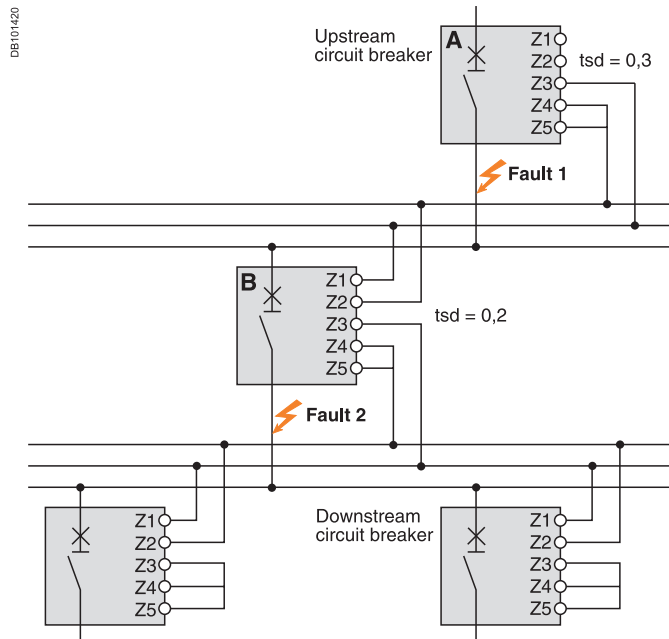

Additional
characteristics



<i>Functions and characteristics</i>	A-1
<i>Installation recommendations</i>	B-1
<i>Dimensions and connection</i>	C-1
<i>Electrical diagrams</i>	D-1
Tripping curves	E-2
<i>Catalogue numbers and order form</i>	F-1

Tripping curves

ET2.0 Trip System

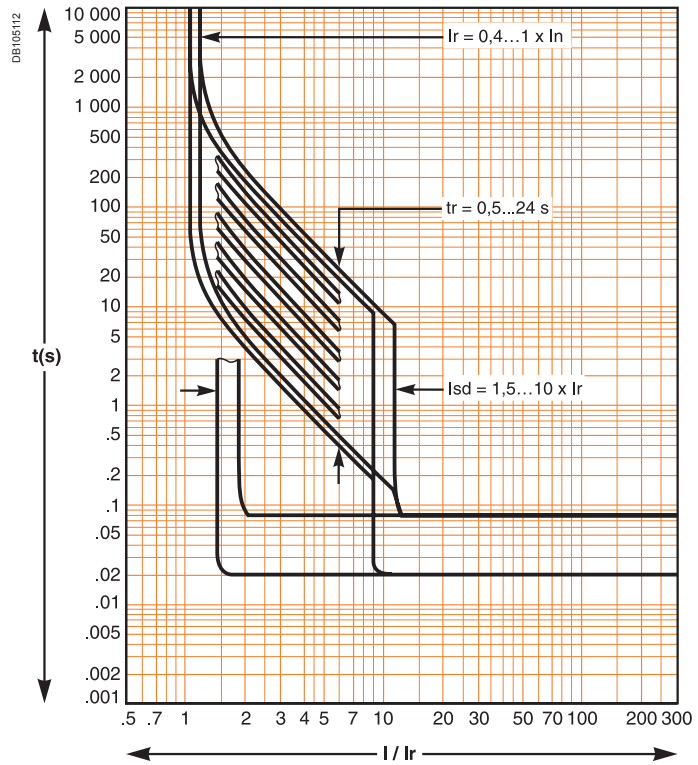

ET6G Trip System

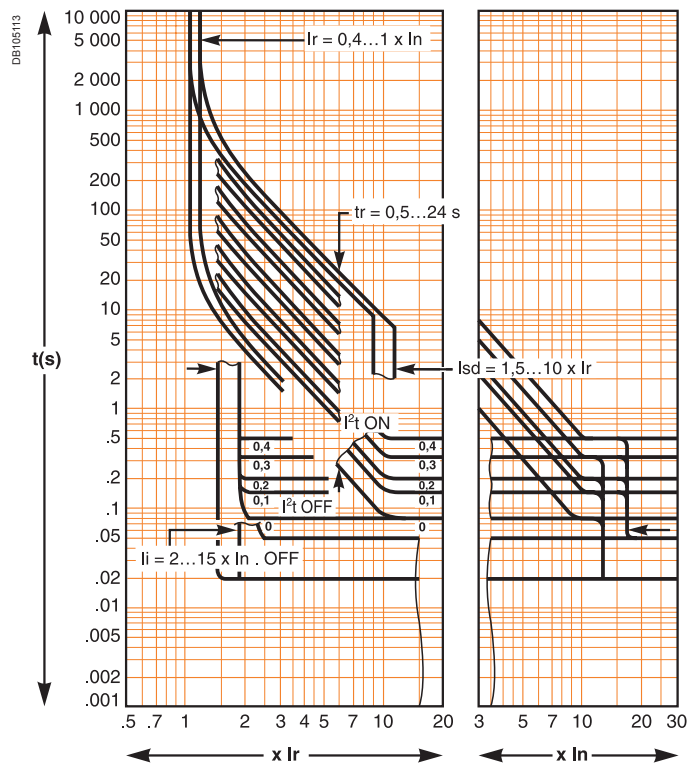

Earth fault protection (ET6G Trip System)

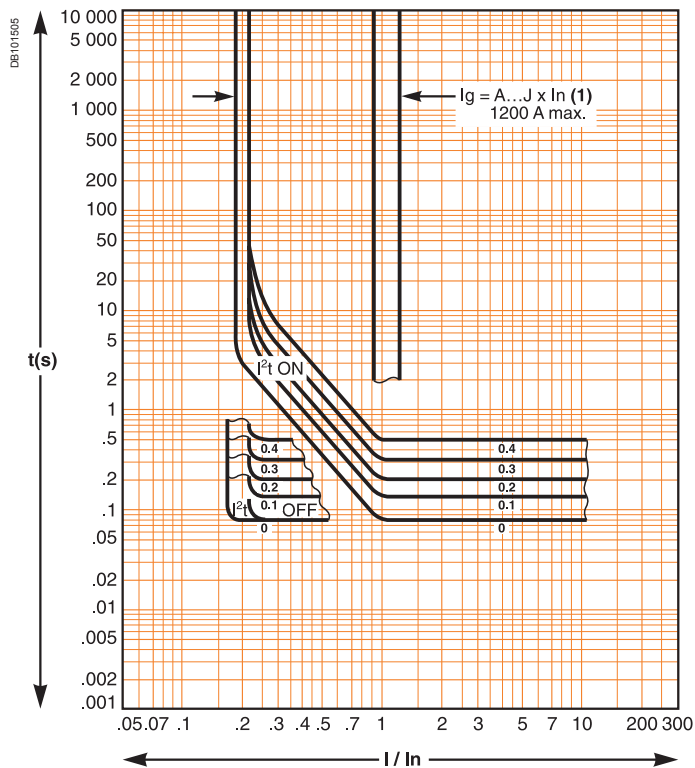

(1)

$I_g = I_n \times \dots$	A	B	C	D	E	F	G	H	J
$I_n \leq 400 \text{ A}$	0.3	0.3	0.4	0.5	0.6	0.7	0.8	0.9	1
$400 \text{ A} < I_n \leq 1000 \text{ A}$	0.2	0.3	0.4	0.5	0.6	0.7	0.8	0.9	1
$I_n \geq 1250 \text{ A}$	500	640	720	800	880	960	1040	1120	1200

Catalogue numbers and order form



Catalogue numbers and order form

<i>Functions and characteristics</i>	A-1
<i>Installation recommendations</i>	B-1
<i>Dimensions and connection</i>	C-1
<i>Electrical diagrams</i>	D-1
<i>Tripping curves</i>	E-2
Nomenclature	F-2
<hr/>	
EasyPact SPS 800 to 1600A	F-3
EasyPact SPS fixed	F-3
EasyPact SPS withdrawable	F-4
<hr/>	
EasyPact SPS	F-5
Connection	F-5
ET Trip System & accessories	F-6
Remote operation	F-7
Chassis locking and accessories	F-9
Clusters	F-10
Circuit breaker locking and accessories	F-11
Mechanical interlocking for source changeover	F-12
Indication contacts	F-13
<hr/>	
Order form	F-15

Range	Current rating	Type	Pole	Operating mechanism	Installation	Protection No.	Type
EasyPact SPS (from 800 to 1600A) Ics = 100%Icu = 50kA, Icw (1 sec) = 42kA for circuit breaker & 36kA for switch-disconnector							
SPS	08 10 12 16	F	3P 4P	M E	F W	2 6 0	B L D
3	2	1	2	1	1	1	1
							12 digits
							Type
							B Basic protection without display and LED indication
							L Basic protection without display but with LED indication
							Protections No.
							2 LI protection
							6 LSIG protection
							0 No protection for switch disconnector
							Type of installation
							F Fixed
							W Withdrawable/drawout
							Operating mechanism
							M Manual type ACB/SD
							E Electrical type with MCH + XF + MX
							Number of poles
							3P 3 Poles
							4P 4 Poles
							Type based on breaking capacity
							F Circuit breaker Ics = 100%, Icu = 50kA, Icw (1 sec) = 42kA
							Switch-disconnector Icm = 75kA, Icw (1 sec) = 36kA
							Current rating
							08 800A
							10 1000A
							12 1250A
							16 1600A

Example 1

SPS12F3PMW2B

SPS	12	F	3P	M	W	2	B
EasyPact SPS	1250A	50kA	3 Pole	Manual type	Withdrawable type	LI protection	Basic trip unit without any Indication

EasyPact SPS fixed type with ET trip unit

CDB500062

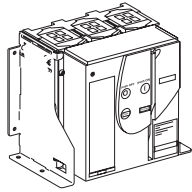

		3P		4P	
		ET2.0	ET6G	ET2.0	ET6G
Manual	800A	SPS08F3PMF2B	SPS08F3PMF6L	SPS08F4PMF2B	SPS08F4PMF6L
	1000A	SPS10F3PMF2B	SPS10F3PMF6L	SPS10F4PMF2B	SPS10F4PMF6L
	1250A	SPS12F3PMF2B	SPS12F3PMF6L	SPS12F4PMF2B	SPS12F4PMF6L
	1600A	SPS16F3PMF2B	SPS16F3PMF6L	SPS16F4PMF2B	SPS16F4PMF6L
Electrical ⁽¹⁾	800A	SPS08F3PEF2B	SPS08F3PEF6L	SPS08F4PEF2B	SPS08F4PEF6L
	1000A	SPS10F3PEF2B	SPS10F3PEF6L	SPS10F4PEF2B	SPS10F4PEF6L
	1250A	SPS12F3PEF2B	SPS12F3PEF6L	SPS12F4PEF2B	SPS12F4PEF6L
	1600A	SPS16F3PEF2B	SPS16F3PEF6L	SPS16F4PEF2B	SPS16F4PEF6L

EasyPact SPS fixed type Switch Disconnecter

CDB500062

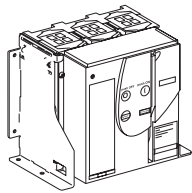

		3P	4P
Manual	800A	SPS08F3PMF0D	SPS08F4PMF0D
	1000A	SPS10F3PMF0D	SPS10F4PMF0D
	1250A	SPS12F3PMF0D	SPS12F4PMF0D
	1600A	SPS16F3PMF0D	SPS16F4PMF0D
Electrical ⁽¹⁾	800A	SPS08F3PEF0D	SPS08F4PEF0D
	1000A	SPS10F3PEF0D	SPS10F4PEF0D
	1250A	SPS12F3PEF0D	SPS12F4PEF0D
	1600A	SPS16F3PEF0D	SPS16F4PEF0D

⁽¹⁾ Supplied with spring charge motor(MCH), opening release(MX) and closing release(XF) with requested control voltage rating.

Use customer order form in page F-9 to specify coil voltages for electrical type breaker & to order optional accessories

EasyPact SPS 800 to 1600A

EasyPact SPS withdrawable type

EasyPact SPS withdrawable type with ET trip unit

CB550048

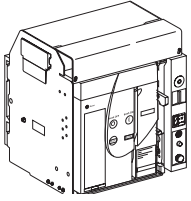

		3P		4P	
		ET2.0	ET6G	ET2.0	ET6G
Manual	800A	SPS08F3PMW2B	SPS08F3PMW6L	SPS08F4PMW2B	SPS08F4PMW6L
	1000A	SPS10F3PMW2B	SPS10F3PMW6L	SPS10F4PMW2B	SPS10F4PMW6L
	1250A	SPS12F3PMW2B	SPS12F3PMW6L	SPS12F4PMW2B	SPS12F4PMW6L
	1600A	SPS16F3PMW2B	SPS16F3PMW6L	SPS16F4PMW2B	SPS16F4PMW6L
Electrical ⁽¹⁾	800A	SPS08F3PEW2B	SPS08F3PEW6L	SPS08F4PEW2B	SPS08F4PEW6L
	1000A	SPS10F3PEW2B	SPS10F3PEW6L	SPS10F4PEW2B	SPS10F4PEW6L
	1250A	SPS12F3PEW2B	SPS12F3PEW6L	SPS12F4PEW2B	SPS12F4PEW6L
	1600A	SPS16F3PEW2B	SPS16F3PEW6L	SPS16F4PEW2B	SPS16F4PEW6L

EasyPact SPS withdrawable type switch disconnect

CB550048

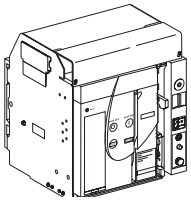

		3P	4P
Manual	800A	SPS08F3PMW0D	SPS08F4PMW0D
	1000A	SPS10F3PMW0D	SPS10F4PMW0D
	1250A	SPS12F3PMW0D	SPS12F4PMW0D
	1600A	SPS16F3PMW0D	SPS16F4PMW0D
Electrical ⁽¹⁾	800A	SPS08F3PEW0D	SPS08F4PEW0D
	1000A	SPS10F3PEW0D	SPS10F4PEW0D
	1250A	SPS12F3PEW0D	SPS12F4PEW0D
	1600A	SPS16F3PEW0D	SPS16F4PEW0D

⁽¹⁾ Supplied with spring charge motor(MCH), opening release(MX) and closing release(XF) with requested control voltage rating.
Use customer order form in page F-9 to specify coil voltages for electrical type breaker & to order optional accessories

Connection

3P 4P

Fixed circuit breakers

Rear connection (vertical mounting) / Replacement kit (3 or 4 parts)

E46445

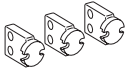

800-1250 A	Vertical	MVS31111	MVS31112
1600 A	Vertical	33584	33585

Vertical mounting.

Drawout circuit breakers

Rear connection (vertical mounting) / Replacement kit (3 or 4 parts)

E46445

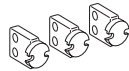

800-1250 A	Vertical	MVS31115	MVS31116
1600 A	Vertical	33586	33587

Vertical mounting.

Connection accessories

Interphase barriers / Replacement kit (3 parts)

E46428



For fixed rear-connected circuit breaker	33648	33648
For drawout rear-connected circuit breaker	33768	33768

Spreaders (Spare/ replacement kit 800-1600A)

For fixed and drawout rear-connected circuit breakers	MVS31109	MVS31110
---	----------	----------

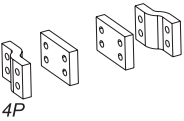
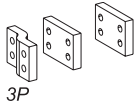

ET Trip System & accessories

ET trip units & accessories

Trip units

CD5500057

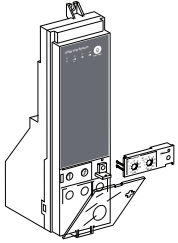

ET2.0 protection relay	MVS15514
ET6G protection relay	67479

Battery + cover

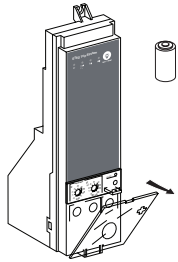

Battery (1 part)	For Micrologic 6G	33593
Cover (1 part)		33592

External sensors

External sensor for earth-fault protection (TCE) / 1 part

E44871

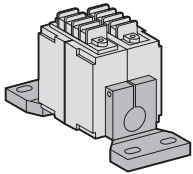

Sensor rating	400/1600 A	33576
---------------	------------	-------

Test equipments / 1 Part

CD5500038

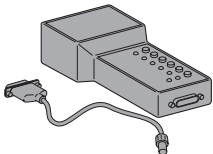

Hand held test kit (HHTK)	33594
---------------------------	-------

Remote operation

Gear motor

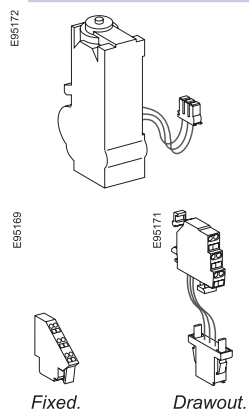

MCH (1 part)

AC 50/60 Hz	48 V	33186
	100/130 V	33176
	200/240 V	33177
	277/415 V	33179
	440/480 V	33179
	+resistor	33193
DC	24/30 V	33185
	48/60 V	33186
	100/125 V	33187
	200/250 V	33188
Terminal block (1 part)	For fixed circuit breaker	47074
	For drawout circuit breaker	33098

Closing release (XF)

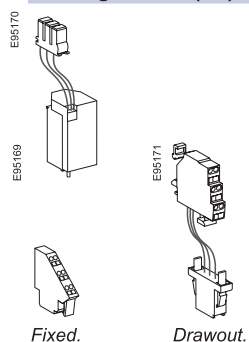

Standard coil (1 part)

AC 50/60 Hz	24/30 V DC, 24 V AC	33659
	48/60 V DC, 48 V AC	33660
	100/130 V AC/DC	MVS15511
	200/250 V AC/DC	MVS15512
	380/480 V AC	MVS15513
DC		
Terminal block (1 part)	For fixed circuit breaker	47074
	For drawout circuit breaker	33098

Opening release (MX)

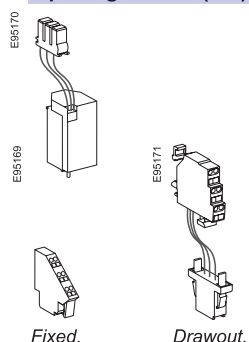

Standard coil (1 part)

AC 50/60 Hz	24/30 V DC, 24 V AC	33659
	48/60 V DC, 48 V AC	33660
	100/130 V AC/DC	33661
	200/250 V AC/DC	33662
	380/480 V AC	33664
DC		
Terminal block (1 part)	For fixed circuit breaker	47074
	For drawout circuit breaker	33098

Remote operation

Undervoltage release MN

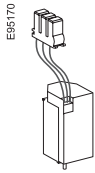

Undervoltage release (1 part)

AC 50/60 Hz	24/30 V DC, 24 V AC	33668
DC	48/60 V DC, 48 V AC	33669
	100/130 V AC/DC	33670
	200/250 V AC/DC	33671
	380/480 V AC	33673
Terminal block (1 part)	For fixed circuit breaker	47074
	For drawout circuit breaker	33098

E95169

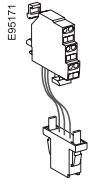

Fixed.

Drawout.

MN delay unit

E46894

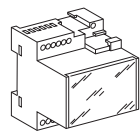

MN delay unit (1 part)

		R (non-adjustable)	Rr (adjustable)
AC 50/60 Hz	48/60 V AC/DC		33680
DC	100/130 V AC/DC	33684	33681
	200/250 V AC/DC	33685	33682
	380/480 V AC/DC		33683

Chassis locking

"Disconnected" position locking

DB117108.eps

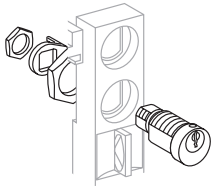

By padlocks		
	VCPO	Standard
By Profalux keylocks		
Profalux	1 lock with 1 key + adaptation kit	64909
	2 locks 1 key + adaptation kit	61910
By Ronis keylocks		
Ronis	1 lock with 1 key + adaptation kit	64912
	2 locks 1 key + adaptation kit	64913

Door interlock (1 part)

DB117066.eps

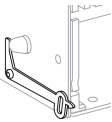

Right or Left-hand side of chassis (VPECD or VPECG)	33172
---	-------

Chassis accessories

Auxiliary terminal shield (CB)

DB117104.eps

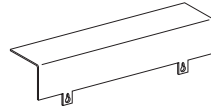

Terminal shield	3P	33763
	4P	33764

Safety shutters + locking / 1part

DB117103.eps

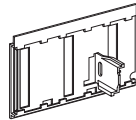

Safety shutters (VO)	3P	33765
	4P	33766

Note: The locking of safty shutters is integrated

Clusters

Clusters

ES9538

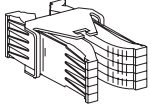

1 disconnecting contact cluster for chassis (see table below) (part 1)

64906

Table : number of clusters required for the different chassis models

Chassis rating (A)	EasyPact SPS	
	3P	4P
800	6	8
1000	6	8
1250	6	8
1600	12	16

Racking handle

ES9561

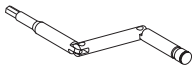

Racking handle

47098

Circuit breaker locking

Pushbutton locking device / 1 part

E46686

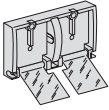

By padlocks	33897
-------------	-------

OFF position locking / 1 part

E46735

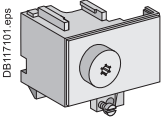

By Profalux keylocks

Profalux	Profalux 1 lock+ 1 key (without adaptation kit)	42888
	Profalux 2 locks + 1 key (without adaptation kit)	42878
	Adaptation kit (without key locks)	MVS31117

By Ronis keylocks

Ronis	Ronis 1 lock+ 1 key (without adaptation kit)	41940
	Ronis 2 locks + 1 key (without adaptation kit)	41950
	Adaptation kit (without key locks)	MVS31113

Escutcheon and accessories / 1 part

CDB600061

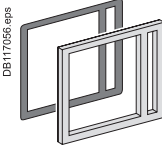

Escutcheon

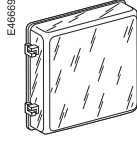

Cover

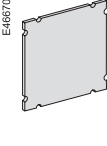

Blanking plate

	Fixed	Drawout
Escutcheon	33718	33857
Transparent cover (IP 54)	-	33859
Escutcheon blanking plate	-	33858

Front cover (3P / 4P) / 1 part

CDB600056

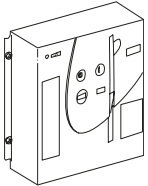

Front cover	MVS31114
-------------	----------

Spring charging handle / 1 part

E95536



Spring charging handle	47092
------------------------	-------

Arc chute for EasyPact SPS / 1 part

CDB600059

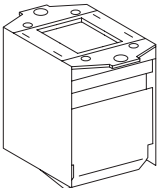

Type F	3P	4P
	3 x 47095	4 x 47095

Mechanical interlocking for source changeover

Mechanical interlocking for source changeover

Interlocking of 2 devices using cables ⁽¹⁾

CD8500063

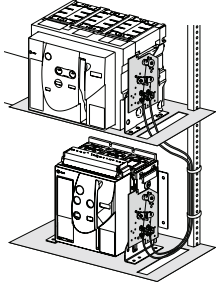

Choose 2 adaptation sets (1 for each device + 1 set of cables)

1 adaptation fixture for EasyPact SPS fixed devices

33200

1 adaptation fixture for EasyPact SPS drawout devices

33201

1 set of 2 cables

33209

(1) Can be used with any combination of SPS or MVS, fixed or drawout devices.

Indication contacts

ON/OFF indication contacts (OF) / 1 part

DB402837 eps

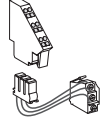

Changeover contacts (6 A - 240 V)	47076
Wiring	For fixed circuit breaker For drawout circuit breaker
	47074 33098

"Ready to close" contact (1 max.) / 1 part

DB402876 eps

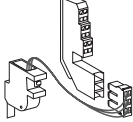

	PF
1 changeover contact (5 A - 240 V)	47080
Wiring	For fixed circuit breaker For drawout circuit breaker
	47074 33098

Carriage switches (connected / disconnected / test position) / 1 part

DB402916 eps

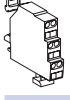

Changeover contacts (6 A - 240 V)	
1 connected position contact (1 max.)	33170
1 test position contact (1 max.)	33170
1 disconnected position contact (1 max.)	33170

Auxiliary terminals for chassis alone

DB404399 eps

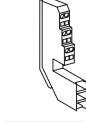

3 wire terminal (1 part), terminal block (1 part)	33098
Jumpers (10 parts)	47900

Order ref no:

Date:

Product ref no:

EasyPact SPS

Circuit breaker and Switch-disconnectors Customer Order form

To indicate your choices, check the applicable square boxes

And enter the appropriate information in the rectangles

Circuit breaker or switch-disconnector Quantity

Rating	A	<input type="text"/>
Circuit breaker	F	<input type="text"/>
Switch Disconnector	FA	<input type="text"/>
Number of poles	3 or 4	<input type="text"/>
Type of equipment	Fixed	<input type="text"/>
	Draw out with chassis	<input type="text"/>
Operating Mechanism	Manual Operated	<input type="text"/>
	Electrical Operated	<input type="text"/>
MCH - Gear motor		<input type="text"/> V
XF - Closing coil		<input type="text"/> V
MX - Shunt/Opening voltage release		<input type="text"/> V

ET Range of Trip System

ET-Without display 2.0 6G

LR - Long-time rating plug **Standard** 0.4 to 1 Ir

Connection

Vertical spreaders

Optional for 800 & 1000A Top Bottom

Must for 1250 & 1600A **Standard**

Trip System functions:
 2.0 : Basic protection (long time + inst.)
 6G : Selective + earth-fault protection
 (long time + short time + inst. + earth-fault)

Indication contacts

OF - ON/OFF indication contacts			
Standard	2 OF Contacts	6 A-240/380V AC	<input type="text"/>
Additional	1 OF Contact	6 A-240/380V AC	<input type="text"/>
	2 OF Contacts	6 A-240/380V AC	<input type="text"/>

SDE - "fault-trip" indication contact			
Standard	1 SDE	5A -240/380V AC	<input type="text"/>

Optional

Carriage switches				8 A-240/380V AC	<input type="text"/>
CE - "Connected" position	Max. 1		qty	<input type="text"/>	
CT - "Test" position	Max. 1		qty	<input type="text"/>	
CD - "Disconnected" position	Max. 1		qty	<input type="text"/>	
Remote tripping				V	<input type="text"/>
	MN - Under voltage release			<input type="text"/>	
	R - Delay unit (fixed time delay)	0.25s		<input type="text"/>	
	Rr - Adjustable delay unit	0.5s.....3s		<input type="text"/>	
TCE - External sensor (NCT) for neutral of 3 Phase-4 Wire systems				400/1600 A	<input type="text"/>
PF - "Ready to close" contact				5A-240/380V	<input type="text"/>

Locks

VBP - ON/OFF pushbutton locking (by transparent cover using padlock)				<input type="text"/>	
VSPO - Device locking in OFF position by key lock (Only one key lock per ACB possible)				<input type="text"/>	
	Key lock kit (w/o key lock)	Profalux	<input type="text"/>	Ronis	<input type="text"/>
	1 key lock	Profalux	<input type="text"/>	Ronis	<input type="text"/>
	2 identical key locks, 1 key	Profalux	<input type="text"/>	Ronis	<input type="text"/>

Chassis locking in "Disconnected" position:

VSPD - by key locks	Key lock kit (w/o key lock)	Profalux	<input type="text"/>	Ronis	<input type="text"/>
	1 key lock	Profalux	<input type="text"/>	Ronis	<input type="text"/>
	2 identical key locks, 1 key	Profalux	<input type="text"/>	Ronis	<input type="text"/>

Door interlock - VPEC	On left-hand side of chassis (LH)	<input type="text"/>
	On right-hand side of chassis (RH)	<input type="text"/>

Accessories

VO - Safety shutters on chassis	Standard	<input type="text"/>
CDP - Escutcheon	Standard	<input type="text"/>
CP - Transparent cover for escutcheon		<input type="text"/>
OP - Blanking plate for escutcheon		<input type="text"/>
CB - Auxiliary terminal shield fitted on chassis		<input type="text"/>
EIP - Interphase barriers		<input type="text"/>
HHTK - Hand held test kit		<input type="text"/>

Notes:
 Customer can provide the reference no. of the product for the listed references. Kindly refer to product catalogue for list of references.
 All breakers will be provided with 2 OF (2 c/o contacts), 1 SDE (trip contact), Escutcheon (Panel sealing frame) as standard.
 All draw-out type devices will be supplied with Chassis & safety shutter.
 For Electrical operated devices, indicate the voltage ratings of MCH, XF & MX
 Refer to product catalogue for available voltage ratings of MCH/XF/MX/MN.
 All SPS products are supplied with vertical type customer connecting terminals.

Schneider Electric Industries SAS

35, rue Joseph Monier
CS 30323
F- 92506 Rueil Malmaison Cedex

RCS Nanterre 954 503 439
Capital social 896 313 776 €
www.schneider-electric.com

As standards, specifications and designs change from time to time, please ask for confirmation of the information given in this publication.



This document has been printed on ecological paper

*Design: Schneider Electric
Photos: Schneider Electric
Printed:*